

2015

# A CONTINUOUS ROTARY ACTUATION MECHANISM FOR A POWERED HIP EXOSKELETON

Matthew C. Ryder

*University of Massachusetts Amherst*

Follow this and additional works at: [https://scholarworks.umass.edu/masters\\_theses\\_2](https://scholarworks.umass.edu/masters_theses_2)

 Part of the [Biomechanical Engineering Commons](#), [Biomechanics and Biotransport Commons](#), [Biomedical Devices and Instrumentation Commons](#), [Computer-Aided Engineering and Design Commons](#), [Controls and Control Theory Commons](#), [Electro-Mechanical Systems Commons](#), [Robotics Commons](#), and the [Systems and Integrative Engineering Commons](#)

---

## Recommended Citation

Ryder, Matthew C., "A CONTINUOUS ROTARY ACTUATION MECHANISM FOR A POWERED HIP EXOSKELETON" (2015). *Masters Theses*. 242.

[https://scholarworks.umass.edu/masters\\_theses\\_2/242](https://scholarworks.umass.edu/masters_theses_2/242)

This Open Access Thesis is brought to you for free and open access by the Dissertations and Theses at ScholarWorks@UMass Amherst. It has been accepted for inclusion in Masters Theses by an authorized administrator of ScholarWorks@UMass Amherst. For more information, please contact [scholarworks@library.umass.edu](mailto:scholarworks@library.umass.edu).

**A CONTINUOUS ROTARY ACTUATION MECHANISM FOR A POWERED HIP  
EXOSKELETON**

Thesis Presented

by

**MATTHEW CHARLES RYDER**

Submitted to the Graduate School of the  
University of Massachusetts Amherst in partial fulfillment  
of the requirements for the degree of

**MASTER OF SCIENCE IN MECHANICAL ENGINEERING**

May 2015

Mechanical and Industrial Engineering

© Copyright by Matthew C. Ryder 2015

All Rights Reserved

**A CONTINUOUS ROTARY ACTUATION MECHANISM FOR A POWERED HIP  
EXOSKELETON**

A Thesis Presented

by

**MATTHEW CHARLES RYDER**

Approved as to style and content by:

---

Frank C. Sup IV, Chair

---

James Rinderle, Member

---

Yossi Chait, Member

---

Donald Fisher, Department Head  
Mechanical and Industrial Engineering

## DEDICATION

This thesis is dedicated to my hardworking and loving parents, Charles and Valerie Ryder, who have stood by and supported me since the day I was born and without whom I would not be who I am today.

## ACKNOWLEDGMENTS

I would like to thank my thesis advisor, Frank Sup, for guiding me down the path of success as well as my lab-mates and friends for their help and experience getting this project off the ground.

## ABSTRACT

### A CONTINUOUS ROTARY ACTUATION MECHANISM FOR A POWERED HIP EXOSKELETON

MAY 2015

MATTHEW CHARLES RYDER

M.S.M.E., UNIVERSITY OF MASSACHUSETTS, AMHERST

Directed by: Professor Frank C. Sup IV

This thesis presents a new mechanical design for an exoskeleton actuator to power the sagittal plane motion in the human hip. The device uses a DC motor to drive a Scotch yoke mechanism and series elasticity to take advantage of the cyclic nature of human gait and to reduce the maximum power and control requirements of the exoskeleton. The Scotch yoke actuator creates a position-dependent transmission that varies between 4:1 and infinity, with the peak transmission ratio aligned to the peak torque periods of the human gait cycle. Simulation results show that both the peak and average motor torque can be reduced using this mechanism, potentially allowing a less powerful motor to be used. Furthermore, the motor never needs to reverse direction even when the hip joint does. Preliminary testing shows the exoskeleton can provide an assistive torque and is capable of accurate position tracking at speeds covering the range of human walking. This thesis provides a detailed analysis of how the dynamic nature of human walking can be leveraged, how the hip actuator was designed, and shows how the exoskeleton performed during preliminary human trials.

## TABLE OF CONTENTS

	Page
ACKNOWLEDGEMENTS .....	v
ABSTRACT .....	vi
LIST OF FIGURES .....	ix
CHAPTER	
1. OVERVIEW AND OUTLINE .....	1
Project Overview .....	1
Thesis Outline .....	3
2. PRIOR WORK .....	5
Introduction .....	5
Prior Work .....	6
Hybrid Assistive Limb (HAL) .....	6
Ekso Bionics eLegs™ .....	8
Hocoma Lokomat™ .....	9
Lower Extremity Powered Exoskeleton (LOPES) .....	10
Limitations of Prior Work .....	11
3. LEVERAGING GAIT DYNAMICS TO IMPROVE EFFICIENCY AND PERFORMANCE OF POWERED HIP EXOSKELETONS .....	13
Introduction and background .....	13
Sagittal Plane Hip Dynamics .....	14
Torque, Angle and Power of the Hip Sagittal Plane .....	14
General Scotch Yoke Mechanisms .....	16
The Mechanism .....	18
Equations of Motion .....	20
Theoretical Performance .....	22
Reduction in Torque Variation .....	23
Reduction in Speed Variation .....	24
Conclusion and future work .....	24
4. MECHANICAL DESIGN OF ACTUATOR .....	25
Drawback of Motor Reversal .....	25
Overview of the Design .....	28



Motor and Transmission .....	31
Series Elastic Elements .....	36
5. CONTROL APPROACH .....	38
6. MECHANICAL EVALUATION AND HUMAN SUBJECT TESTING .....	43
Mechanical Evaluation .....	43
Human Testing.....	48
Passive vs Active Torque.....	51
7. CONCLUSIONS AND FUTURE WORK .....	54
REFERENCES .....	58

## LIST OF FIGURES

Figure	Page
1-1: Exoskeleton mounted to hip joint during preliminary human trials .....	1
2-1: HAL 5 exoskeleton.....	6
2-2: Ekso exoskeleton.....	8
2-3: Lokomat gait trainer .....	9
2-4: LOPES gait trainer .....	11
3-1: Torque, angle and power of human hip joint in the sagittal plane. ....	15
3-2: Illustrates how the Scotch yoke mechanism moves hip from fully extended (1) to fully flexed (3). See Figure 2-1 for alignment with gait cycle. ....	16
3-3: Device mounted to side of user as well as detailed view of the mechanism. ....	17
3-4: Simplified sketch of the mechanism labeling important dimensions and angles .....	20
3-5: Theoretical torque and velocity profiles.....	23
4-1: Typical mass and inertia of leg segments for a 75kg male.....	25
4-2: Scotch yoke mechanism to convert continuous rotary motion into reciprocating linear motion. Mechanism has variable transmission ratio. ....	28
4-3: Reciprocating yoke is attached to leg bar via steel cables. Green cable guide maintains angle between cable and leg bar to keep moment arm constant. ....	29
4-4: Series elastic springs inside hollow tubes on the yoke.....	30
4-5: Hip and wheel velocities over the gait cycle. ....	31
4-6: Power required at worm wheel to reproduce healthy human gait. ....	32
4-7: Maxon EC30 torque-speed curve showing operating conditions in blue. ....	33
4-8: Normalized hip and wheel torque profiles showing reduction in torque variation .....	34
4-9: Comparison of required motor torque for fixed gearing vs Scotch yoke. ....	35
5-1: Graphical representation of the lookup table the exoskeleton builds during its calibration procedure. ....	39
5-2: Block diagram of the stiffness controller used to control the exoskeleton.....	42
6-1: Position tracking of 0.25 Hz sine wave. ....	43

6-2: Position tracking of 0.5 Hz sine wave .....	44
6-3: Position tracking of 1.0 Hz sine wave. ....	44
6-4: Position tracking of 2 Hz sine wave. ....	44
6-5: Position tracking of 3 Hz sine wave. ....	45
6-6: Position tracking of a sine wave reference (0.25 Hz) with a stiff controller. ....	46
6-7: Position tracking of a sine wave reference (4 second period) with a soft controller. ....	46
6-8: The controller in learning mode .....	47
6-9: Exoskeleton mounted to human subject. ....	48
6-10: Reference and actual trajectories for several steps. ....	49
6-11: Torque and position data when the user fights the exoskeleton and it provides its peak torque. ....	51
6-12: Interaction torque between the exoskeleton and user for several gait cycles .....	52

# CHAPTER 1

## OVERVIEW AND OUTLINE

### Project Overview

People recovering from leg injuries and those suffering from diseases, such as multiple sclerosis, that effect muscle function often require physical therapy to help restore natural gait. Physical therapy consists of a team of therapists guiding the patient's leg toward the correct position and can be very tiring for the therapist depending on the weight of the patient. In other situations, the patient uses hand rails to support themselves while shuffling their feet and tires quickly due to the stress on his/her upper body. In both situations the rehabilitation is typically confined to the rehabilitation facility and the patient must make weekly trips while struggling to be mobile at home.

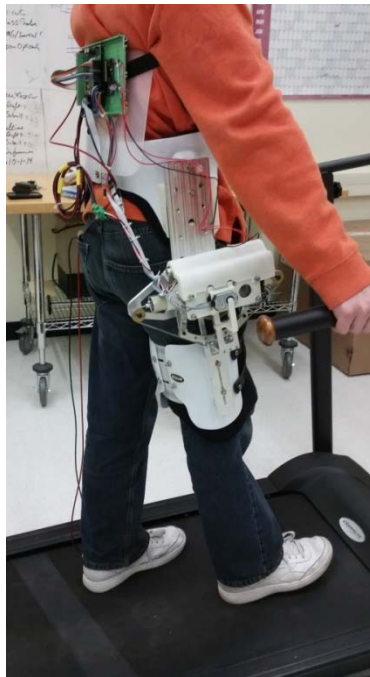

**Figure 1-1: Exoskeleton mounted to hip joint during preliminary human trials**

Recently, robotic exoskeletons have been designed to ease the demand on physical therapists and continue rehabilitation at home. These exoskeletons primarily use electric motors

to provide assistance to the patient, where the motor is coupled to a gearhead that reverses direction with each step. This method has been proven to work, but little to no research has been done to explore the use of continuous rotary actuation. These mechanisms convert unidirectional rotation to reciprocating linear motion. This thesis presents an exoskeleton that uses such a mechanism to assist persons with weakened muscles in a rehabilitation environment by providing up to 50% of the torque at the hip joint required to walk in the sagittal plane. The sagittal plane runs front to back through the center of a person and is the primary plane of motion for walking. It is designed for flat, level ground walking and is tuned to one person's step size so adjustments must be made before using it on another person. The prototype assists people weighing up to 90 kg and only actuates the hip joint of one leg in the sagittal plane. The exoskeleton incorporates many subsystems that work together to accomplish this task.

First, the human gait cycle was studied to determine its general shape, peak torque and speed requirements and subject-to-subject variations. An important observation of the human gait cycle is that the highest speeds occur when the torque is lowest and the lowest speeds occur when torque is highest. A continuous rotary mechanism, called a Scotch yoke mechanism, with series elastic elements was then designed to provide assistive power to the user without reversing motor direction. The Scotch yoke mechanism has a continuously variable transmission ratio designed to align with key parts of the human gait cycle (low transmission ratio during high speed periods, high ratio during low speed periods). Series elastic elements are used to reduce force impulses between the exoskeleton and the user to improve comfort, allow for measurement of the interaction force by measuring spring displacement, and absorb energy during negative power phases of the gait cycle to reduce the torque requirement of the motor.

Next, a stiffness controller was implemented to control the exoskeleton in a way that allowed a reference trajectory to be followed but also limited the interaction forces between the user and the exoskeleton. The stiffness controller is used in contrast to a traditional position tracking controller where the amount of motor effort depends only on the error between the

reference trajectory and the actual trajectory. For a situation where the robot is interacting with humans this control scheme is not ideal because the robot could hurt the person if it is not able to obtain feedback. By designing a control law based on both the position error and the interaction force between the user and exoskeleton, the amount of assistive torque provided depends on the position error and the amount of torque already being provided. By controlling two gain terms the perceived stiffness of the mechanism can be varied to provide differing amounts of assistive torque. In a low stiffness situation the exoskeleton will provide torque to follow the reference trajectory but if a small interaction force exists the exoskeleton will slow down or stop until the user moves and the interaction force is reduced. This is a “patient-in-charge” interaction. In a high stiffness situation the exoskeleton will continue to follow the reference trajectory until the interaction force is much higher, in which case it will stop and wait until the user moves their leg closer to where it should be. This is a “robot-in-charge” interaction.

By combining information about the patient’s gait cycle with a stiffness controller the exoskeleton was able to provide just over 44 Nm of torque to help a 71 kg healthy, male subject walk during preliminary testing. It was also able to follow reference trajectories with speeds varying from 0.25 Hz to 2 Hz; a range typical of human gait. The remainder of this thesis will show how the exoskeleton was designed, how it helps restore normal gait through both passive and active means and show what its limitations are. This research demonstrates the viability of a continuous rotary actuator for a hip exoskeleton and provides a foundation for future work based on the same concept.

### **Thesis Outline**

This thesis starts by discussing prior work in the field of powered assistive exoskeletons designed for rehabilitation. The actuation and control schemes of these exoskeletons are different yet all accomplish a similar task. Next, a conference paper describing the theory behind the exoskeleton designed for this thesis is presented. This paper was published in the IEEE

proceedings from the International Conference on Rehabilitation Robotics and gives background on the human gait cycle along with the basic layout of the exoskeleton along with early simulation results showing its ability to assist in walking.

The next chapter describes in great detail the benefits of the continuous rotary actuation mechanism from an energy and control standpoint. It is shown that by allowing the mechanism to stop the leg at each end of motion instead of using motor power a significant improvement of battery life can be realized and the average torque demand on the motor can be reduced. The design criteria for the motor and transmission are then worked out along with the criteria for the series elastic spring elements. The stiffness controller used in this exoskeleton is also discussed in this chapter.

Chapter 6 shows the results of bench testing by having the exoskeleton follow sine waves varying from 0.25 Hz to 3 Hz. Stable control is achieved up until ~2 Hz, which is less than desirable but adequate for human gait since healthy humans walk at approximately 0.75 Hz. The effect of changing the controller stiffness is also explored in this chapter, where the exoskeleton is run into a hard stop in both high and low stiffness modes to show the differences in interaction force before the exoskeleton stops trying to push harder.

Chapter 6 also describes the human testing procedure and shows preliminary results of how the exoskeleton performs on one healthy human subject. The exoskeleton first collects gait data on the subject and then uses this data to build a reference trajectory to help them follow. While the user walks on a treadmill the exoskeleton outputs the reference trajectory, the actual trajectory and the assistive torque being provided. Finally, conclusions and future work are discussed along with suggested improvements to the design.

## CHAPTER 2

### PRIOR WORK

#### Introduction

Exoskeletons are mechanical devices that provide power to human joints using electric, hydraulic or pneumatic actuators. The ideal lower-limb exoskeleton would be as flexible and as easy to wear as a pair of pants, would have negligible mass compared to the user, and would provide the correct amount of torque at each of the several joints in the leg and hip. Since these goals aren't achievable with current technology, compromises must be made. Modern exoskeletons are heavy (weighing about 40lbs [2,4]) actuate a subset of the hip/leg joints and restrict the natural motion of the user due to the way the exoskeletons attach to the user. Despite their drawbacks, exoskeletons can be used in rehabilitation settings to aid physical therapy and train people to walk again. [7]

Modern exoskeletons rely primarily on electric motors, although some still use hydraulic and pneumatic actuators. The HAL uses DC motors coupled with harmonic drive gearheads to actuate the knee joint and the hip joint in the sagittal plane. Harmonic drives provide a large reduction ratio in a small package and are used in all of the HAL actuators. Similarly, the Argo Technologies ReWalk™, Ekso Bionics eLegs™ and the powered orthosis presented by Farris *et al* [8] are all operated by DC motors, where the first two operate via linear actuators and the latter by a driven chain mechanism. These devices are similar to the HAL system, but with only the hips and knees being actuated. The BLEEX system powers the ankle, hip and knee joints in the sagittal plane by hydraulic actuators, using one for each joint. The stationary LOPES device uses flexible Bowden cables to actuate the hip and knee joints while the user is walking on a treadmill. The actuators and control circuitry for LOPES are located elsewhere in the room. All of these devices actuate the hip and knee joints in the sagittal plane and they require the actuators to reverse direction each time a



joint reaches the end of its range of motion. A summary of each of these exoskeletons is given below.

### **Prior Work**

#### **Hybrid Assistive Limb (HAL)**

The earliest HAL exoskeleton (Figure 2-1) was designed and built by researchers at the University of Tsukuba in Japan [2]. In 2004 these researchers formed Cyberdyne Inc. to further develop the exoskeleton. The HAL comes in two variants: the HAL-3, which only supplies power to the lower limbs, and the HAL-5 which supplies power to the upper body as well. Both are



**Figure 2-1: HAL 5 exoskeleton**

intended to help the elderly and disabled people regain their strength and mobility. DC motors coupled with harmonic drive gearheads power the hip and knee joints in the sagittal plane while the battery provides just less than 3 hours of continuous use. The controller and other electronics are housed in a backpack. The DC motors and gearheads are capable of rotating 360 degrees continuously so mechanical stops are used to prevent injury to the user. Rotary encoders at both joints provide position feedback and strain gauges measure torque. A pressure sensor is mounted

to the bottom of each foot to gain information about what phase of walking the user is in. The HAL is able to communicate wirelessly with a Linux-based computer to adjust system parameters and evaluate the user's performance.

The 50 lb HAL is controlled by reading the myoelectric signals from the user's muscles and estimating the joint torques they intended to produce based on those signals [10]. The conversion factors between myoelectric signal and torque is determined experimentally by recursive least squares for each user. Strain gauges are used to measure the actual amount of torque the user is producing at the joint and the difference between the intended torque and the actual torque is the error the HAL exoskeleton works to minimize [11].

Early clinical evaluations have shown that the HAL suit is able to increase stride frequency and length in 25% of mobility-impaired patients [13], with a greater improvement seen on stride frequency [12]. However, the HAL does not seem to be well suited for all rehabilitation patients. Patients with severe paralysis or who suffer from involuntary neuron firing will not benefit from the HAL since it relies on neuron signals to decide when to provide assistance [13]. Patients that had some previous experience with gait training benefitted more from the HAL than those who were new to gait training, although patients who had established their own new gait pattern did not benefit from the HAL. All patients experienced an increased metabolic cost as compared to with walking without the HAL. Patients who used the HAL in conjunction with a cane experienced a much larger increase in their metabolic cost of walking than those who used a handrail with the HAL. Roughly half of the patients had a lower metabolic cost of walking the day after using the HAL, indicating it was easier for them to walk after being trained with the HAL even though they were no longer wearing it.

Cyberdyne currently has 330 HAL suits leased out to 150 hospitals and other facilities for a cost of \$1,950 per year [16]. In February 2013 the HAL was given a global safety certificate, the first step toward global distribution.

## **Ekso Bionics eLegs™**

The research that led to the Ekso Bionics eLegs™, exoskeleton started originally at the University of California in 2004 as the Berkeley Lower Extremity Exoskeleton (BLEEX). The eLegs™ (Figure 2-2) actuates the hip and knee joints in the sagittal plane (BLEEX also actuated the ankle) via hydraulic actuators and can supply a peak hip torque of 150Nm [4]. The batteries,



**Figure 2-2: Ekso exoskeleton**

computer and compressor are carried in a backpack, with the entire exoskeleton weighing 45lbs and having a battery life of 6 hours. The overall efficiency of eLegs™ is only 14%, which is typical of hydraulic systems and leaves much room for improvement [4].

Unlike the HAL, eLegs™ does not use sensors on the person's skin to detect myoelectric signals and with the exception of a pressure sensor under the foot, does not make any measurements at the human-exoskeleton interfaces [15]. Instead, each joint has many sensors including encoders and linear accelerometers that determine each segment's position, velocity and acceleration. Using inverse dynamics, eLegs™ infers what the torques and loads must have been

based on how eLegs™ moves. The foot plates each have four pressure sensors (heel, mid-foot, ball of foot and toes) to determine the user's weight distribution and gather information about the gait cycle.

### **Hocoma Lokomat™**

The Hocoma Lokomat™ (Figure 2-3) is a treadmill-based gait trainer developed at the Spinal Cord Injury Center of the University Hospital Balgrist in Switzerland in 1999 [14]. It uses one linear actuator at each hip and knee joint to provide assistance in the sagittal plane only. A total of four linear actuators are used and their motion is controlled via four xPC Matlab-based



**Figure 2-3: Lokomat gait trainer**

proportional-derivative (PD) controllers. Precision potentiometers are used to measure the instantaneous angle of each of the four joints while force sensors measure the interactions between the user and device [18]. Lokomat's power supply and controller are located off-board and an overhead harness is used to support an adjustable amount of the user's weight. To make the device more comfortable for the user, two control strategies were originally implemented. Unlike the HAL, which tries to assist the user take the step they would ordinarily try to take, Lokomat's first controller enforces the 'correct' gait pattern by using data collected from healthy individuals. This forces the patient to match the step size, frequency and movement pattern of a healthy person. The

second is an impedance controller, which allows the user to deviate from the ‘correct’ gait pattern but guides them back if they stray too far [18]. Both strategies can result in the patient standing still and doing nothing while the Lokomat moves their legs for them. This removes motivation for the patient to try walking under their own power. More recently, a Patient-Driven Motion Reinforcement (PDMR) control scheme was implemented [18,19] which uses both a position and force controller coupled with an inverse dynamics algorithm to more accurately adapt to the patient’s intentions. Essentially, the Lokomat tries to determine how much torque is needed to take a step and supplies a fixed percentage of that torque. This lets the patient control their own gait speed, however the patient must be able to generate some motion on their own as the Lokomat is no longer in complete control but rather responding to the user’s motions.

### **Lower Extremity Powered Exoskeleton (LOPES)**

Another treadmill-based gait trainer, the Lower Extremity Powered Exoskeleton (LOPES) depicted in Figure 2-4, was developed at the Institute for Biomedical Technology at the University of Twente, Netherlands [7]. LOPES uses flexible steel Bowden cables actuated by off-board electric motors to power the hip joint in both the sagittal and frontal planes as well as the knee joint in the sagittal plane. The maximum torque of each joint in the sagittal plane is 65 Nm [7]. The LOPES controller can switch between “patient in charge” mode where the exoskeleton follows the user and provides little assistance, and “robot in charge” mode where the exoskeleton follows a healthy gait pattern and the user is essentially along for the ride. A major difference between LOPES and other gait training exoskeletons is that LOPES incorporates series elastic actuators (SEA), which is essentially a spring in series with the actuator and the joint being actuated [23]. This turns a force-control problem into a position-control problem since the relationship between force and position is known for a given spring. Control bandwidth is significantly reduced due to the added compliance [7]. The control of LOPES is further complicated by the use of Bowden cables, as the friction in these cables varies over time and as a function of tension, bend angle and

velocity. Since it is not possible to determine the amount of frictional losses in advance, force

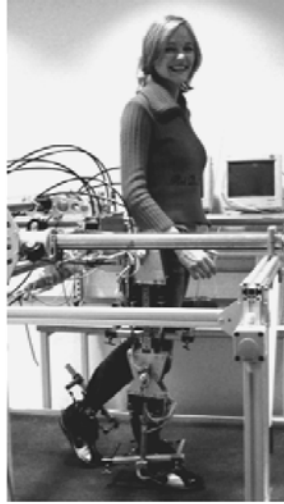

**Figure 2-4: LOPES gait trainer**

sensors are located *after* the cables so the effective contribution from friction can be compensated for. Using Bowden cables allows for larger motors to be used because they are located off-board and the user does not have to carry their weight.

### **Limitations of Prior Work**

These exoskeletons rely mainly on electric motors and hydraulic cylinders for actuation. The HAL uses DC motors coupled with harmonic drive gearheads to actuate the knee joint and the hip joint in the sagittal plane. Harmonic drives can provide a large, fixed reduction ratio in a small package and require the motor to reverse direction twice per step. Similarly, LOPES and Lokomat are powered by DC motors and use ball screws for linear actuation. These devices are similar to the HAL system because there is a fixed transmission ratio between the motor and the user's leg. The Ekso system powers the hip joint via hydraulic actuators that use an electric motor for the compressor. The moment arm of the hydraulic cylinders varies as the joint rotates, but no effort is made to leverage this situation to improve the performance of the exoskeleton. While all of these devices actuate the hip joint in the sagittal plane, they also require the actuators to reverse direction

each time a joint reaches the end of its range of motion and have fixed transmission ratios, which increase the torque requirements and power losses of the motor. The Scotch yoke mechanism described in this thesis can help solve these problems by employing a position-dependent transmission ratio that has periods of peak torque during the gait cycle aligned with the locations of the highest transmission ratio in the mechanism.

## CHAPTER 3

### LEVERAGING GAIT DYNAMICS TO IMPROVE EFFICIENCY AND PERFORMANCE OF POWERED HIP EXOSKELETONS

*This chapter was originally published as a conference paper at the 2013 IEEE International Conference on Rehabilitation Robotics. It has been adapted for use in this thesis. References and figure numbering have been updated to be compatible with the formatting of this thesis.*

Ryder, MC and Sup, F, "Leveraging gait dynamics to improve efficiency and performance of powered hip exoskeletons." *Proceedings of the IEEE International Conference on Rehabilitation Robotics*, 2013.

#### **Introduction and background**

Exoskeletons are mechanical devices that provide power to human joints using electric, hydraulic or pneumatic actuators. They are often used to help people with limited or impaired mobility train their muscles and walk better than they would otherwise be able to. Powered exoskeletons for rehabilitation have been designed for use in medical centers and research facilities and have become much smaller and lighter over the past decade. Some of these exoskeletons have on-board power supplies and control units such as the Cyberdyne Hybrid Assistive Limb (HAL) [2], Argo Technologies ReWalk™ [1] and Berkeley's BLEEX [4] which was the predecessor of Ekso Bionics' eLEGS™, while other stationary clinical rehabilitation devices are tethered to a computer and do not have the power supply attached to the user (Lokomat [5] and LOPES [6][7]).

The Hardiman from the 1960s was powered primarily by hydraulics via an 18.7 kW (25 HP) compressor running at 3,000 psi. With improvements in computation, motors and batteries, more recent exoskeletons rely primarily on electric motors. The HAL uses DC motors coupled with harmonic drive gearheads to actuate the knee joint and the hip joint in the sagittal plane. Harmonic drives provide a large reduction ratio in a small package and are used in all of the HAL actuators. Similarly, the ReWalk™, eLEGS™ and the powered orthosis presented by Farris *et al* [8] are all operated by DC motors, where the first two operate via linear actuators and the latter by a driven



chain mechanism. These devices are similar to the HAL system, but with only the hips and knees being actuated. The BLEEX system powers the ankle, hip and knee joints in the sagittal plane by hydraulic actuators, using one for each joint. The stationary LOPES device uses flexible Bowden cables to actuate the hip and knee joints while the user is walking on a treadmill. The actuators and control circuitry for LOPES is located elsewhere in the room. While all of these devices actuate the hip and knee joints in the sagittal plane, they also require the actuators to reverse direction each time a joint reaches the end of its range of motion.

The contribution of this paper is the development of a continuous mechanism to actuate the sagittal plane motion of the human hip. First, the typical motion of the hip's sagittal plane during a normal gait cycle will be presented, followed by a description of the mechanism and a discussion of its benefits over traditional hip actuators. Finally, the future development of this mechanism will be discussed.

### **Sagittal Plane Hip Dynamics**

#### **Torque, Angle and Power of the Hip Sagittal Plane**

The cyclic nature of the sagittal plane gait cycle can be seen in Figure 3-1. This data is typical of the healthy human gait cycle shown in [9]. Plots A and B of Figure 3-1 show how the hip angle and torque vary in a quasi-sinusoidal manner from a peak at heel strike<sup>1</sup> (0%), a low at about 50% of the cycle, and then another peak at the next heel strike (100%). The peak sagittal plane torque is 1.3 Nm/kg and the peak flexion angle is 22 degrees.

The power generated or absorbed by the hip joint is shown in Figure 3-1(c). It can be seen that the hip generates positive power for the individual until 35% of the gait cycle. Positive power means the individual's muscles are generating power to propel them forward. After the 35% mark the hip angle crosses zero and corresponds to the point when the individual's leg is

---

<sup>1</sup> The peak occurs just after heel strike

completely vertical. At this point, passive structures such as tendons and muscle fascia stretch and absorb energy which stops the hip from extending any further. These structures exert the negative torque seen in Figure 3-1(a). Since energy is being absorbed and dissipated<sup>2</sup> by passive tissue during this phase the power generation is negative and it is possible for passive mechanical

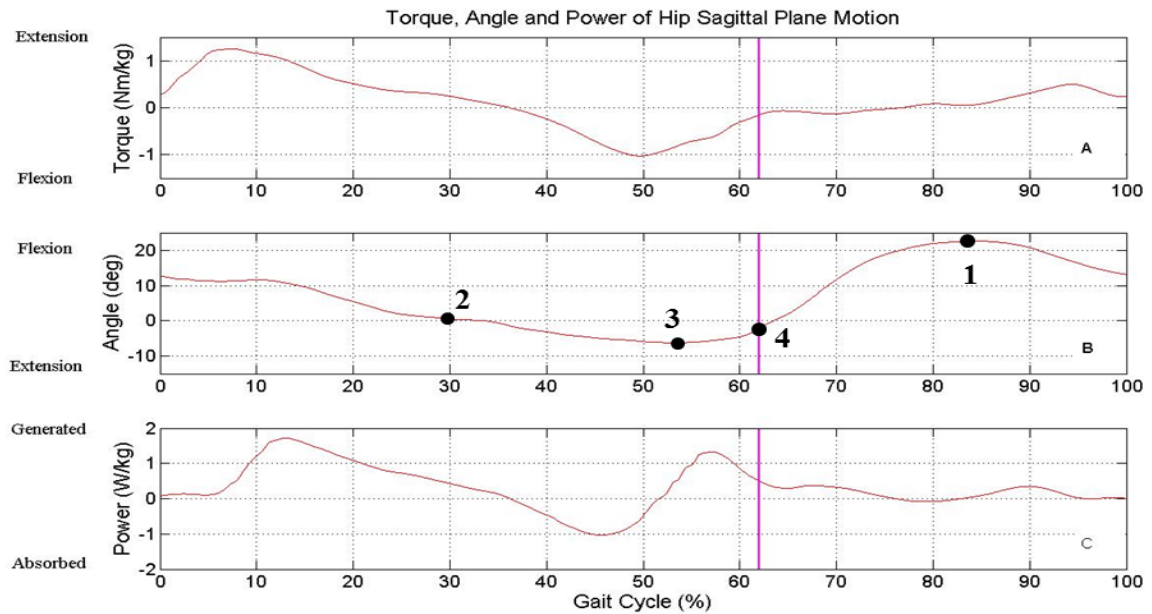

**Figure 3-1: Torque, angle and power of human hip joint in the sagittal plane. The solid vertical line denotes the toe-off point where the swing phase begins. The 0% and 100% points are heel strikes. Torque and power are scaled based on the individual’s mass and have units of Nm/kg and W/kg, respectively. The number points in B correspond to the four phases of the mechanism in Figure 3-2. Data from [9].**

elements, such as springs, to absorb this energy instead of human tissue. Doing this would allow energy to be stored and later released during the next peak of positive power generation. This will be discussed in the next section of this paper. After toe-off (indicated by solid vertical line) the power remains minimal during the swing phase.

<sup>2</sup> Energy is stored, not dissipated, by the passive joint structures.

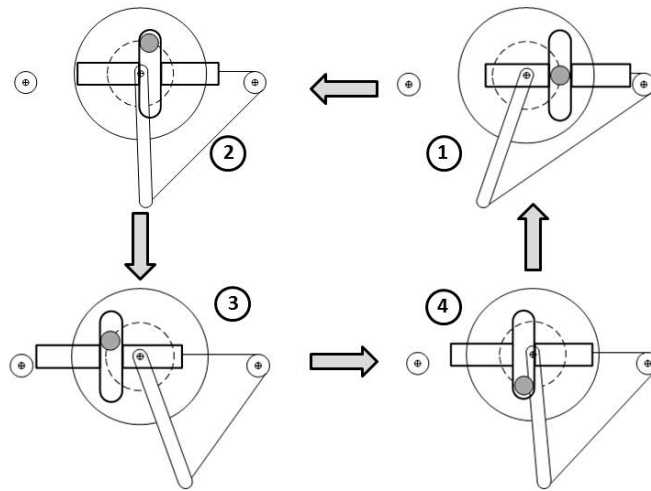

**Figure 3-2: Illustrates how the Scotch yoke mechanism moves hip from fully extended (1) to fully flexed (3). See Figure 2-1 for alignment with gait cycle.**

### General Scotch Yoke Mechanisms

Since the torque and angle profiles in Figure 3-1 are cyclic in nature, it makes sense to use an actuator that is inherently cyclic as well. Other exoskeletons, such as the HAL, use DC motors coupled with harmonic gearheads to actuate joints. This requires reversing motor direction and overcoming significant inertia each time the joint reaches the end of its range of motion. These types of drive mechanisms also have a fixed gear ratio which means the motor must change speed dramatically when transitioning from periods of high torque and low speed to periods of high speed and low torque. These types of transitions happen with every gait cycle, as can be seen in Figure 3-1(b) just after toe-off. The slope of this plot represents the angular velocity of the joint and it is much higher during the swing phase than at any time before or after that phase. It can also be seen that just after toe-off during the swing phase the torque requirement hovers very closely to zero. Conversely, just after heel strike Figure 3-1 shows that the angular velocity is very low and the torque is at its peak. Clearly, during the swing phase it would be advantageous to have a smaller transmission ratio between the motor and the joint and just after heel strike it would be better to have a larger transmission ratio. Having a variable transmission would allow the motor to

spin at a more constant speed and would reduce the variation in motor current due to changes in the torque.

To realize a variable transmission that changes in a sinusoidal manner the Scotch yoke

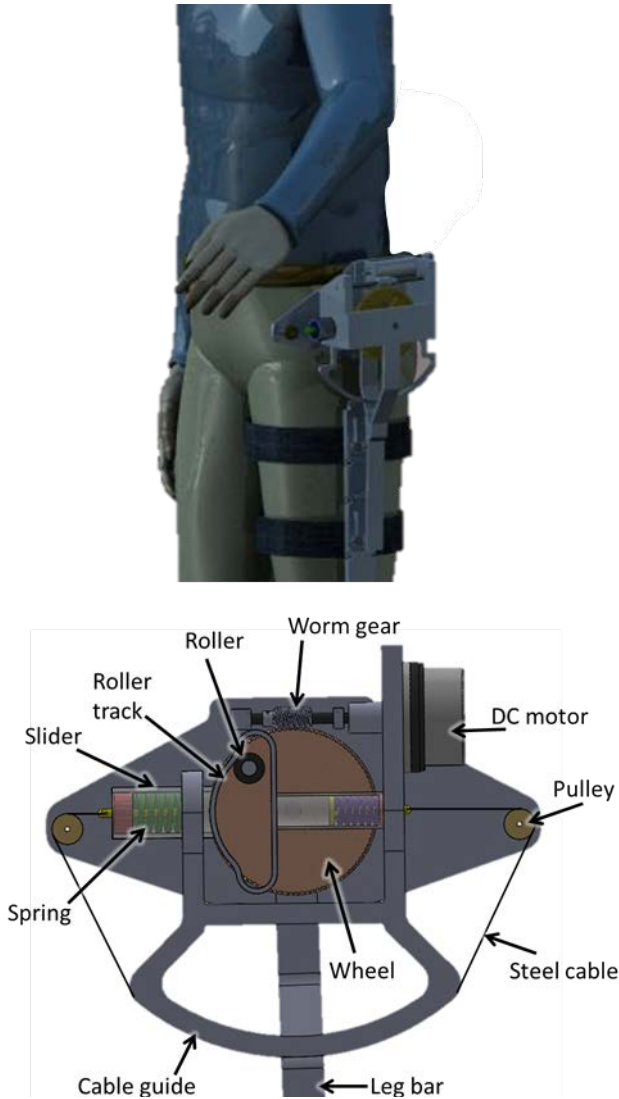

**Figure 3-3: Device mounted to side of user as well as detailed view of the mechanism.**

mechanism was used. Scotch-yoke mechanisms convert continuous rotary motion into reciprocating linear motion and have been used in valve control applications, internal combustion and steam engines [21-22]. These mechanisms are similar to a crank and slider mechanism in that the linear output moves in a sinusoidal pattern except Scotch yoke mechanisms have fewer moving

parts and are capable of higher torque output. Figure 3-2 shows a full cycle of this mechanism and it starts with the slider all the way to the right. As the wheel rotates counterclockwise the roller attached to the wheel pushes the slider to the left. After the wheel has rotated 180 degrees the slider reaches the end of its range of motion and as the wheel continues to rotate the slider begins to move toward the right. This reciprocating motion continues as long as the wheel continues to turn. When the wheel rotates at a constant velocity the slider reaches its maximum velocities when the wheel is at top dead center and bottom dead center.

### **The Mechanism**

The mechanism used to actuate the hip joint in the sagittal plane is shown in Figure 3-3. This mechanism takes advantage of the cyclically varying transmission ratio of the Scotch yoke mechanism. Periods of peak torque and low speed in the mechanism are lined up with periods of peak torque and low speed of the individual's leg. Similarly, periods of low torque and high speed of the mechanism, at top or bottom dead center, are lined up with the swing phase of the leg since this phase has the highest speed and lowest torque requirements.

A 200 W brushless DC motor turns a worm gear through a 36:1 fixed reduction ratio<sup>3</sup>. This worm gear turns the wheel of the Scotch yoke mechanism. Attached to the wheel is a roller that pushes on a track connected to the slider. As the wheel spins the roller pushes on the track and moves the slider back and forth. A roller is used instead of a sliding peg to reduce frictional losses and to ensure smooth motion. The slider is made up of two hollow tubes (transparent in Figure 3-3 for clarity) with springs inside them to create a series elastic effect. Series elasticity is commonly used in human-machine interfaces and has many benefits such as reduced control bandwidth and improved user comfort [20]. These springs can also be used to measure the torque currently being exerted at the hip joint. Since the springs have a known stiffness and their

---

<sup>3</sup> This ratio was changed to 48:1 in the final design presented in this thesis.

displacement can be easily measured, the force can be determined and the moment can be computed. This eliminates the need for strain gauges to be placed along the leg bar.

Steel cables connect the springs in the slider to the vertical leg bar that attaches to the user's leg. This bar is connected to the mechanism via a pin joint located behind the wheel and as the slider moves left and right it pulls on this steel cable and causes the leg bar to move back and forth. To maintain a constant moment arm a cable guide and two pulleys located at the ends of the slider are used.

One unique feature of this actuation mechanism that doesn't appear in every Scotch yoke mechanism is the dwell that is cut into the left half of the roller track on the slider. This part of the track is cut to have the same radius of curvature as the wheel the roller is connected to, so when the roller enters this region of the track it will no longer be pushing on the track and causing it to move further to the left. This causes the slider to dwell in one location before moving again and it is in this region that the negative power generated by the hip in Figure 3-1(c) can be stored for later use. Since the slider is not actuated in this region, moving the leg bar requires the spring on the left to be compressed by the motion of the user's leg. With the dwell and the spring in place the spring will be compressed as the leg goes backward and the spring will absorb the energy instead of the passive tissues in the user's hip. This energy can be released during the peak of positive power that occurs just after the negative power phase to reduce demands on the DC motor. Knowing the peak hip angle and peak torque, it is possible to compute the spring stiffness necessary to mimic the natural behavior of the user's passive hip structures and successfully store the energy they would normally absorb.

In Figure 3-1(a) it can be seen that the maximum negative hip torque is  $-1.03 \text{ Nm/kg}$ , which equates to  $-92.7 \text{ Nm}$  for a  $90 \text{ kg}$  user. It can also be seen in Figure 3-1(b) that the hip has a maximum extension (moving backwards) angle of  $6.2$  degrees. With an actuator moment arm,  $h$ , of  $10.16 \text{ cm}$  ( $4.0 \text{ in}$ ) the linear displacement of the spring is  $11.00 \text{ mm}$ . A  $10.16 \text{ cm}$  moment arm requires  $912 \text{ N}$  of force to produce the peak torque of  $92.7 \text{ Nm}$ ; the spring must provide  $912 \text{ N}$

when compressed 11.00 mm to provide 100% of the power needed. Since this actuation mechanism is only intended to provide 50% assistance to the user, the spring need only provide a peak of 456 N when compressed 11.00 mm. To meet this requirement, a spring with a stiffness of 41,470 N/m (236.5 lbs/in) was used to absorb the power dissipated during the negative power phase of walking.<sup>4</sup>

### Equations of Motion

Analysis of this mechanism is straightforward and requires a simple torque balance between the force on the wheel from the worm gear and the force on the roller from the slider (simplified drawing shown in Figure 3-4). Eq. 3.1 shows how the torque exerted on the wheel by the motor is amplified by the geometry of the mechanism as well as the current angle of rotation of the wheel.

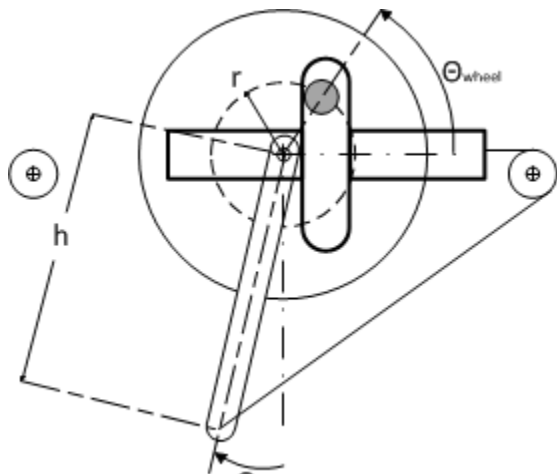

$$\tau_{wheel} = \frac{\tau_{leg} \left( \frac{r}{h} \right) \sin(\Theta_{wheel})}{\eta} \quad \text{Eq. 3.1}$$

$$\frac{\tau_{leg}}{\tau_{wheel}} = \frac{h}{r \sin(\Theta_{wheel})} \eta \quad \text{Eq. 3.2}$$

**Figure 3-4: Simplified sketch of the mechanism labeling important dimensions and angles**

<sup>4</sup> The design used in the original paper used a 6" moment arm that has since been updated to 4". The spring constant has been adjusted accordingly to provide the correct amount of assistive force.

Where  $\tau_{wheel}$  is the torque applied to the wheel from the motor,  $\tau_{leg}$  is the torque required at the leg, determined from biomechanics data,  $\tau_{wheel}$  is the current wheel angle,  $\eta$  is the efficiency<sup>5</sup>,  $r$  is the distance between the center of the wheel and center of the roller,  $h$  is the distance between the center of the wheel and the point where the steel cable connects to the leg bar. Rearranging Eq. 3.1 yields the transmission ratio in given in Eq. 3.2. It can be seen that there is a mathematical singularity in Eq. 3.2 for the case when the wheel angle is at either horizontal extreme: either 0 or  $\pi$ . This singularity creates a theoretically infinite gear ratio. In reality, there is no displacement happening at these extreme points since the slider is at the end of its range of motion, so there is no torque being exerted. Therefore, at these points the efficiency is theoretically undetermined. The forces at these extremes can be thought of as unstable equilibrium points, where a small displacement in either direction will require motor torque to hold it in place but exactly at the equilibrium point it is statically loaded.

The required leg torque at each point in the gait cycle is known from [9]. It can be seen from Eq. 3.1 that the motor must provide the smallest amount of torque when the wheel angle is at 0 or  $\pi$ . By making the periods of peak torque line up with these two wheel positions (7% and 50% of gait cycle from Figure 3-1(a)) less demand<sup>6</sup> will be placed on the motor. Additionally, Eq. 3.3 and Eq. 3.4 show how the angle and velocity, respectively, of the leg bar change with the wheel angle.

$$\Theta_{leg} = \left(\frac{r}{h}\right) \cos(\Theta_{wheel}) + \Theta_{leg\_offset} \quad \text{Eq. 3.3}$$

$$\dot{\Theta}_{leg} = -\left(\frac{r}{h}\right) \sin(\Theta_{wheel}) \dot{\Theta}_{wheel} \quad \text{Eq. 3.4}$$

<sup>5</sup> Efficiency as it is used here accounts for frictional losses from the sliding yoke, roller, cable guide, and spring hysteresis. It does not include the efficiency of the worm gear or DC motor.

<sup>6</sup> The peak and average torque values will go down, reducing the size of motor required



where  $\Theta_{leg\_offset}$  is the leg angle when the wheel angle is zero. This is adjusted when mounting the leg bar to the mechanism to ensure peak transmission ratio of the mechanism lines up with the peak torque regions of the gait cycle.

It can be seen from Eq. 3.4 that the leg reaches its maximum velocity when the wheel angle is at  $\pi/2$  or  $3\pi/2$ ; 90 degrees out of phase with the angles of peak torque. This means that during the wheel's rotation, the regions of peak torque and minimum velocity are offset from the regions of minimum torque and maximum velocity, just like it is in the human gait cycle in Figure 3-1.

It can be seen in Eq. 3.3 that the maximum and minimum leg angles are controlled by the ratio of  $r/h$  and by the leg offset angle. Both of these parameters can be adapted for the specific user when the device is being fitted to them. Changing where along the leg bar the cable connects will change  $h$  and therefore change the ratio, and changing the length of the cable will change the leg offset angle. These adjustments allow the device to work with a wide range of stride lengths and gait patterns.

### **Theoretical Performance**

This section will analyze and discuss how the mechanism described in the preceding section reduces demands on the motor as compared to more standard actuation mechanisms. The reader should note that the mechanism is designed to leverage the dynamic patterns of walking. While it is possible to oscillate the motor direction and not complete a full rotation to actuate small steps, such as those taken when walking first begins or when stopping, efficiency will be lost and the control of the device becomes more complicated. Since most of a person's walking time is spent dynamically walking and not taking an initial step or stopping, this is an acceptable trade off.

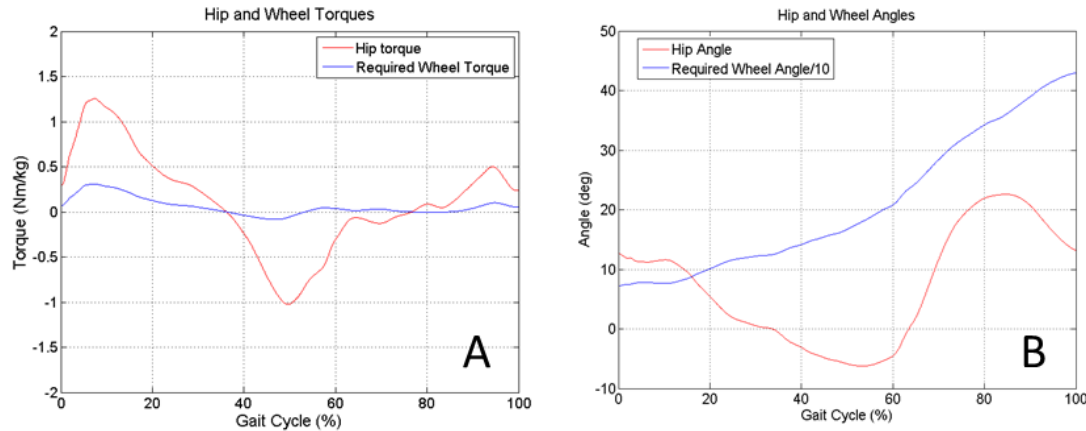

**Figure 3-5: A) Leg torque at hip joint and torque required on wheel of mechanism. Torque curve is significantly reduced and flattened over the gait cycle by using Scotch yoke mechanism. B) Shows how leg angle at the hip in the sagittal plane changes over the gait cycle. Hip angle changes from positive to negative each time the leg is vertical but the mechanism's wheel angle always has the same sign. This means the mechanism does not have to reverse direction to move the leg back and forth. Note that the start and end angles of the wheel are equal because heel strike happens at both 0% and 100% of the gait cycle. The wheel starts at an angle of 72 degrees and ends at an angle of 432 degrees, but by subtracting 360 degrees from 432 it can be seen that the start and stop angles are the same.**

### Reduction in Torque Variation

Figure 3-5(a) compares the required leg torque to the required wheel torque over the gait cycle. It can be seen that despite large variations in the required leg torque, the torque required on the wheel from the motor does not change much. It has a peak of 0.31 Nm/kg just after heel strike and does not go above 0.1 Nm/kg at any other point.

Having a nearly flat torque curve over the entire gait cycle reduces the demand on the motor and worm gearing system. A more uniform force improves the fatigue strength of the gear teeth and improves the life of the motor. It also reduces the demands on the electrical system and reduces the need to design a system capable of handling frequent large current spikes. Furthermore, the drive motor can be slightly undersized since it is only required to provide a large amount of torque for roughly 10% of the gait cycle. This allows the motor to be pushed up to its power limits because it will have the other 90% of the cycle to cool down again.

### **Reduction in Speed Variation**

Along the same lines as the previous section, the Scotch yoke mechanism reduces the variation in the velocity of the wheel as well. Figure 3-5(b) shows that while the slope of the leg angle curve (velocity) changes quite significantly over the gait cycle, the slope of the wheel's angle curve steadily increases.

Another significant benefit of this mechanism is that the motor only spins in one direction. In Figure 3-5(b) it can be seen that while the leg angles changes sign, the required wheel angle is always increasing and thus always spinning the same direction. This greatly reduces the demands of the control system because the motor inertia does not need to be overcome every time the leg reaches the end of its range of motion; this mechanism creates reciprocating linear motion from continuous rotary motion. The next chapter will further show the benefits of a continuous rotary actuator, analyze the mechanical design, and describe the control scheme.

### **Conclusion and Future Work**

This paper has presented a Scotch yoke mechanism for continuously actuating the human hip joint in the sagittal plane. The mechanism was introduced, explained and its performance was evaluated by comparing the torque and velocity requirements of the hip joint and actuator. It was seen in Figure 3-5(a) that the highly variable torque profile of the hip joint can be reduced and flattened by using this type of mechanism.

The next step is to adapt the mechanism to provide assistance to help the user sit and stand. The current mechanism only provides assistance during normal walking but adaptations for sit-to-stand and stand-to-sit transitions exist. One option for doing this would be to passively stretch one of the two springs in the mechanism as the user sits. The potential energy lost by the user lowering themselves would be stored in one of the springs and later released when they wanted to stand back up. Future work will continue with the development and testing of a physical prototype.

## CHAPTER 4

### MECHANICAL DESIGN OF ACTUATOR

#### Drawback of Motor Reversal

The majority of exoskeletons described in the literature that use electric motors require the motors to reverse direction twice with each step. One motor reversal happens when the leg reaches the largest flexion angle and the other occurs when the leg reaches the largest extension angle. Due to the large moments that must be generated at the hip the motors that actuate the hip tend to use large gear reductions typically around 50:1. Each time the motor reverses direction it must stop its own inertia, the inertia of the gearhead and the inertia of the swinging leg. This perpetual reversal wastes a significant amount of energy and increases the torque requirements of

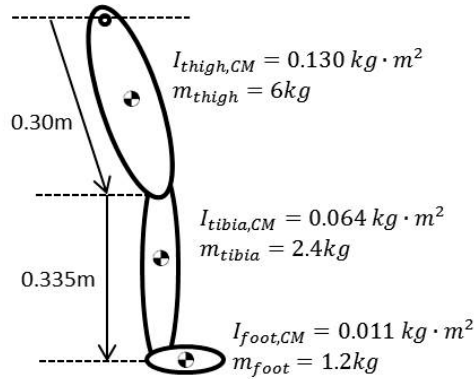

**Figure 4-1: Typical mass and inertia of leg segments for a 75kg male**

the motor. Looking at the following example using a Maxon EC30 brushless motor, a Maxon planetary gearhead (#223090) with a 53:1 reduction ratio and a 75kg male subject (mass and inertia data from [24]) the effects of reversing from a typical speed of 10,000 rpm forward to the same speed backward can be seen. Eq. 4.1 is used to convert the inertias of each leg segment from Figure 4-1 to be about the hip joint instead of their own centers of mass.

$$I_{segment, hip} = I_{segment, CM} + mr^2 \quad \text{Eq. 4.1}$$

Where  $I_{segment, hip}$  is the moment of inertia of a leg segment about the hip joint,  $I_{segment, CM}$  is the moment of inertia of that segment about its own center of mass,  $m$  is the mass of the segment and  $r$  is the linear distance from the segment's center of mass to the hip joint. Solving Eq. 4.1 for the thigh yields  $I_{thigh, hip} = 0.130 + (6)(0.15^2) = 0.175 \text{ kg-m}^2$ . This process is repeated for the tibia and foot segments and then the inertias are added together using Eq. 4.2.

$$I_{leg \text{ about hip}} = I_{thigh, hip} + I_{tibia, hip} + I_{foot, hip} \quad \text{Eq. 4.2}$$

Solving this equation yields the total leg inertia about the hip joint,  $I_{leg \text{ about hip}} = 0.175 + 0.239 + 0.172 \text{ kg-m}^2 = 0.586 \text{ kg-m}^2$ . Next, the leg inertia is combined with the inertia of the gearhead and motor in Eq. 4.3 to find  $I_{total}$ , the total amount of inertia the motor must overcome each time it reverses direction.

$$I_{total} = I_{motor} + I_{gearhead} + \frac{I_{leg \text{ about hip}}}{\beta^2} \quad \text{Eq. 4.3}$$

Since the leg is on the opposite side of the gearhead, it's inertia as seen by the motor is reduced by the square of the reduction ratio,  $\beta$ . The inertias of the EC30 motor and planetary gearhead (taken from product datasheets) are added together with this perceived leg inertia to find the total inertia as seen by the motor.

$$I_{motor} = 33.3 \text{ g-cm}^2 = 33.3e-7 \text{ kg-m}^2$$

$$I_{gearhead} = 17.2 \text{ g-cm}^2 = 17.2e-7 \text{ kg-m}^2$$

$$I_{total} = 33.3e-7 + 17.2e-7 + \frac{0.586}{53^2} \text{ kg-m}^2$$

$$I_{total} = 21.4e-5 \text{ kg-m}^2$$

Once the total inertia is found, the angular acceleration of the inertia is determined. Angular acceleration,  $\alpha$ , is given by Eq. 4.4 as the change in angular velocity,  $\omega_{initial} - \omega_{final}$ , divided by the time,  $t$ , it takes to reverse the inertia.

$$\alpha = \frac{\omega_{initial} - \omega_{final}}{t} \quad \text{Eq. 4.4}$$

If the motor makes a full reversal from +10,000 rpm to -10,000 rpm the required change in angular velocity is  $\Delta\omega = 1047.2 - (-1047.2) = 2094.4 \text{ rad/s}^2$ . According to [9] the leg spends roughly 6% of the gait cycle end the end of travel reversing direction. For a 1.0 second gait period this means full reversal must happen in 60ms, yielding an angular acceleration of  $\alpha = (2094.4)/0.060s \text{ rad/s}^2 = 34,910 \text{ rad/s}^2$ . Finding the torque to move the total inertia at this rate is trivial, as is seen in Eq. 4.5:

$$T_{motor} = I_{total} \alpha \quad \text{Eq. 4.5}$$

The motor must provide a torque of 3.73 Nm, assuming the human subject provides 50% of the required torque. The energy consumed by stopping this amount of inertia is given in Eq. 4.6:

$$KE_{total} = 0.5(I_{total} \omega^2) \quad \text{Eq. 4.6}$$

Stopping the leg and motor with the motor spinning at 10,000 rpm requires 58.53 J assuming subject provides 50% of the required energy. Since there are two motor reversals each gait period, a total of 117.1 Joules is consumed each period. Assuming a gait period of one second, overcoming the inertia of the motor, gearhead, and leg will consume 421,560 J every hour, which is 31% of the total energy contained in a 37V, 10Ahr battery. If it were possible to eliminate the need for motor reversal the battery life of a mobile system could be extended by almost a third. Furthermore, the leg spends roughly 6% of the gait cycle nearly stopped at either end of travel [9] when it reverses direction so the motor must be able to fully reverse in this amount of time. For a gait period of one second this equates to a 60ms reversal time and requires the motor to produce 3.73Nm to reverse the leg direction.

To illustrate why this could be problematic and lead to overdesigned exoskeletons, consider that a healthy human produces a peak torque of 1.25 Nm/kg at the hip during level ground walking [9]. The exoskeleton will be supplying 50% of this, so the exoskeleton must supply 47.1 Nm to the 75 kg subject mentioned earlier. Using the specified 53:1 gearhead this means that to supply the peak torque the motor must provide 0.89 Nm, or about 24% of the torque required to reverse the motor direction in an acceptable amount of time. If the motor did not have

to reverse direction a less powerful motor could be used and it could be operated at a higher peak current since the peak would only occur during peak hip torque and not every time the motor reverses direction.

It should be noted from solving Eq. 4.3 that the inertia of the leg is the dominant inertia that must be overcome each time the leg reaches an end of travel. While traditional transmissions must run the motor to overcome this inertia, the Scotch yoke mechanism locks out at each end of travel and incorporates series springs to slow and stop the leg. The ability to lock in place when it is energetically favorable is a major advantage to this design.

### **Overview of the Design**

Although the design was summarized briefly in Chapter 3, the details behind the design decisions were omitted and will be discussed here. Some of the high level information is repeated to put the discussion in context. To remove the need to reverse motor direction an alternative type of actuation mechanism was designed. This mechanism, called a Scotch yoke mechanism and depicted in Figure 4-2, converts continuous rotary motion into reciprocating linear motion. Power

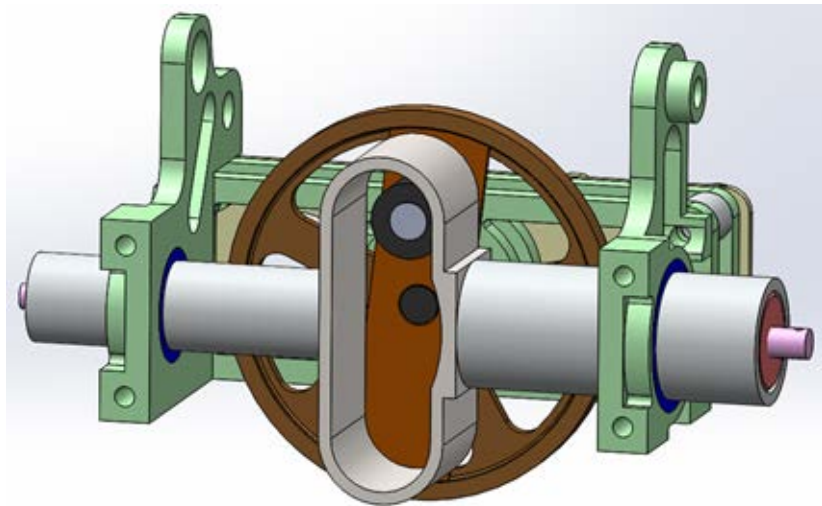
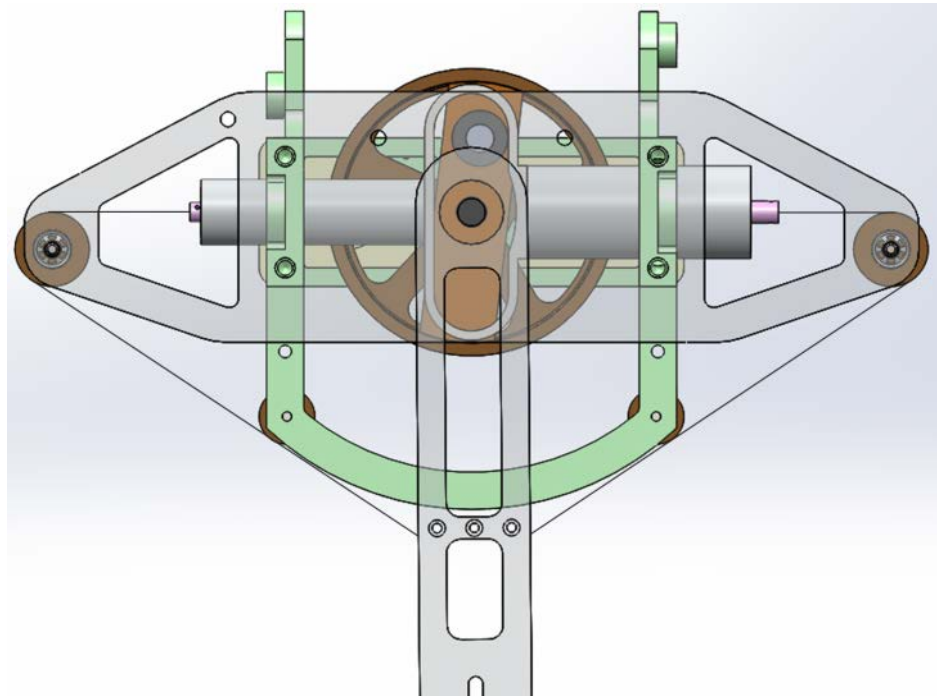

**Figure 4-2: Scotch yoke mechanism to convert continuous rotary motion into reciprocating linear motion. Mechanism has variable transmission ratio.**

is added to the system by rotating the bronze colored wheel with a roller connected to it. As the

wheel rotates clockwise, it pushes on the grey yoke and causes the slider to move to the right. Eventually the slider will reach the end of travel in that direction and as the wheel continues to rotate the roller will push on the other side of the yoke and pull the slider to the left. By controlling the speed of the wheel the period of oscillation can be adjusted. The sinusoidal motion of this mechanism is well suited to assist the human gait cycle because the hip motion of a healthy subject is inherently sinusoidal in nature [3]. Furthermore, torque/speed relationship between the wheel and slider follows a sinusoidal pattern where the slider speed is highest when the roller is at top and bottom dead center and the slider is locked in place at the left and right ends of travel. Since the human gait cycle has periods of high torque with low speed as well as low torque with high speed the variable transmission ratio of this mechanism can be taken advantage of [3].

Cables are used to connect the ends of the slider to a bar that connects to the subject's leg. As the slider oscillates back and forth the cables pull the leg bar and the subject's leg forward and backward. The setup shown in Figure 4-3 uses a guide to keep the cable a constant distance

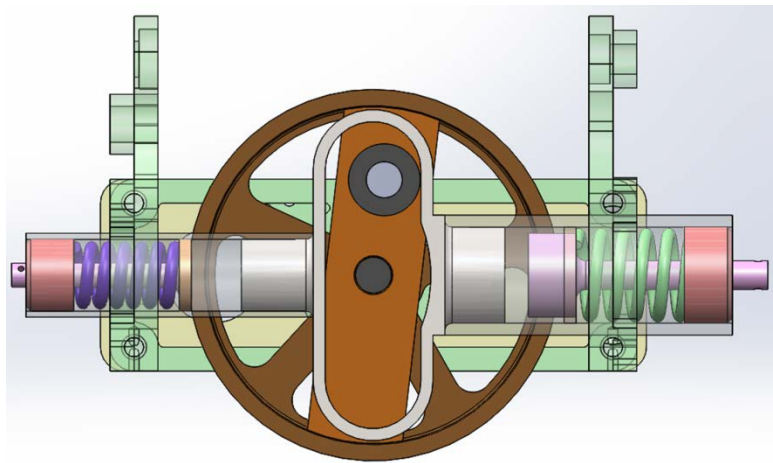

**Figure 4-3: Reciprocating yoke is attached to leg bar via steel cables. Green cable guide maintains angle between cable and leg bar to keep moment arm constant.**



from the leg bar throughout all positions. Without the guide, the angle between the leg bar and cable would change as a function of position so the same linear force in the cable would produce a different amount of torque on the leg bar depending on the current position. Two brass rollers are used to reduce friction between the cable and the cable guide.

Inside the two cylinders are springs in series with the actuator and leg bar (see Figure 4-4). These springs are a proverbial double-edge sword: In addition to reducing the *available* control bandwidth, the springs also reduce the *required* control bandwidth. Springs introduce a delay



**Figure 4-4: Series elastic springs inside hollow tubes on the yoke. Springs connect yoke to the cables to reduce force impulses, reduce required control bandwidth and allow for force measurement.**

between the time the motor starts spinning and the time a specific force is achieved. This reduces the impulse that can be delivered, similar to hammering a nail into a board that is sitting on a mattress. The inability to transfer force instantly both improves user comfort and delays accurate control. If the user is standing upright, small perturbations forward and backward will compress the springs and produce a torque resisting further motion. This can help keep the user upright without using the motor and draining battery power, although the springs add weight to the device. On the other hand, if there is a positioning error it will take longer to achieve the force

necessary to correct that error because it takes time for the springs to compress. Finding the balance between these two constraints will be discussed later.

### Motor and Transmission

Human gait data obtained from Winter [9] and shown in Figure 3-1 was used to determine specifications for the motor and gearing used to drive the Scotch yoke mechanism. A simplified drawing of the mechanism is shown in Figure 3-4. According to [9], during level-ground walking the human hip joint extends 23 degrees before flexing 6 degrees. This means the range of motion of the hip is a total of 29 degrees (approximately 0.50 radians) during each step. For the exoskeleton to allow an end-to-end step of this size the ratio  $\frac{r}{h}$  in Equation 3.3, which controls the amplitude of the step, must be equal to 0.25 radians. This value is then used in Equation 3.1 to solve for the required wheel torque given the hip torque required during the gait cycle. The offset angle,  $\theta_{leg\_offset}$ , applies an offset to the cosine wave produced by this mechanism and is necessary to compensate for the hip's range of motion not being centered about zero

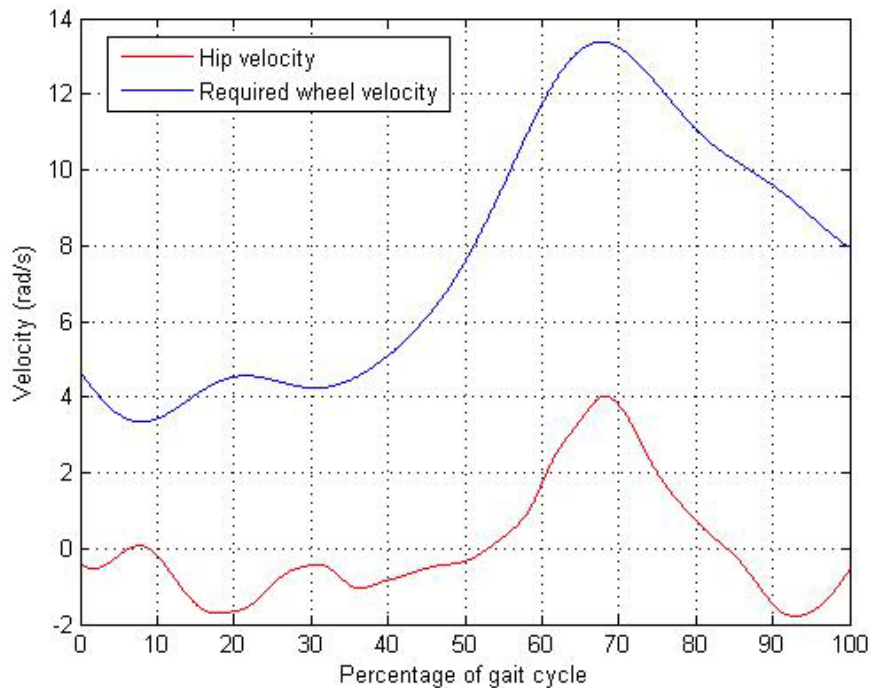
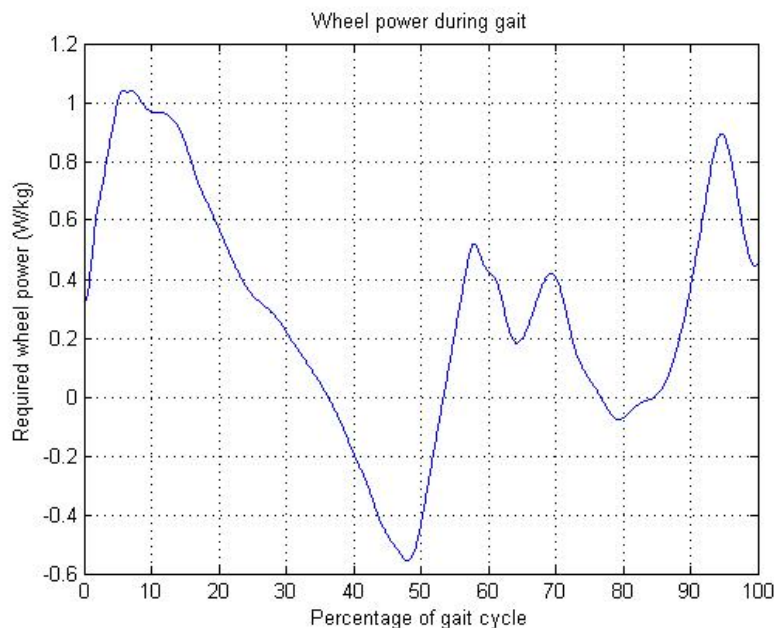

Figure 4-5: Hip and wheel velocities over the gait cycle.

degrees. Since the hip goes flexes 6 degrees and extends 23 degrees the range of motion is centered at 8 degrees extended. When the yoke is in the center of travel ( $\theta_{\text{wheel}} = 90$  degrees) the leg bar is mounted at angle  $\theta_{\text{leg\_offset}} = 8.2$  degrees backwards before the cables connecting the leg bar to the sliding yoke mechanism are attached.

Since it is the ratio of  $\frac{r}{h}$  that controls the stride length, the values can be selected based on other design parameters provided the ratio stays the same. Weight and size should be as small as possible, pushing  $r$  and  $h$  to be smaller, but as this happens the moment arms are reduced and forces go up. To meet both size and range of motion requirements,  $r$  was selected to be 1” and  $h$  was 4”.

Figure 3-5(a) shows the required hip torque at every point in the gait cycle and also shows the wheel torque required to produce the necessary hip torque. The peak hip torque is 1.25 Nm/kg, so for a 90 kg user with 50% assistance the mechanism must produce 56 Nm. The maximum required wheel torque is 0.31 Nm/kg, but since the exoskeleton is only expected to



**Figure 4-6: Power required at worm wheel to reproduce healthy human gait.**

provide 50% assistance it must only provide 0.15 Nm/kg. For the target 90 kg person the wheel must be rotated with 13.9 Nm of torque.

To find the wheel velocity, the position data of the hip was first differentiated to yield the hip velocity profile. Next, Equation 3.2 was used to solve for the wheel velocity knowing the hip velocity. Both velocity profiles are shown in Figure 4-5 and the maximum required wheel velocity is 13.4 rad/s (128rpm). The torque and velocity profiles of the wheel were multiplied together to find the wheel power profile. This plot, Figure 4-6, shows that a peak power of 1.04 W/kg is needed, so for a 90 kg person a motor of at least 93.6 W is needed assuming 100% efficiency. To account for power losses through the worm gear (~50%) and give extra overhead for the prototype, the 200 W Maxon EC30 brushless DC motor was used.

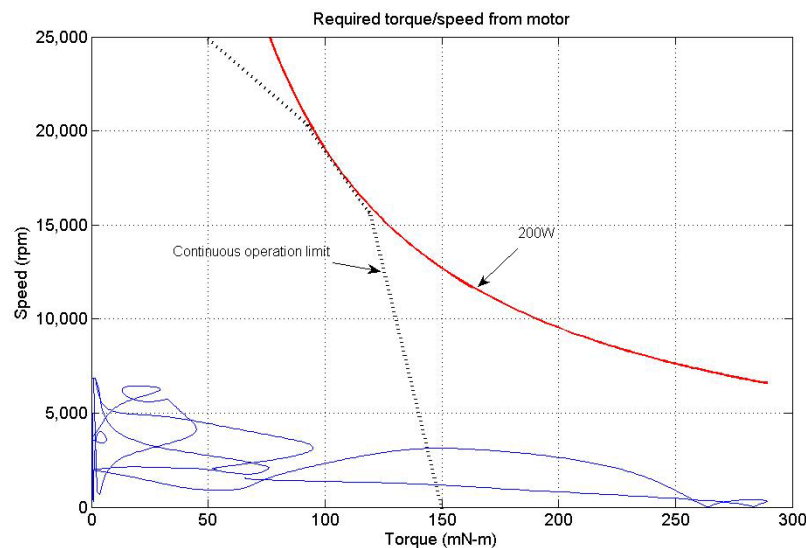

**Figure 4-7: Maxon EC30 torque-speed curve showing operating conditions in blue.**

The Maxon EC30 can deliver 0.131 Nm continuously so to produce the required 13.9 Nm of torque a transmission ratio of at least 106:1 must be used. However, since the nominal speed of the motor is 15,900rpm and the maximum wheel speed is 128 rpm the transmission ratio cannot be larger than 124:1. To allow the motor to correct positioning errors at the maximum anticipated wheel speed, the motor should be capable of spinning between two and three times faster than

this. Letting the wheel spin at 2.5 times the maximum predicted speed sets the upper limit of the transmission ratio at 49:1. Selecting the maximum transmission ratio means that to supply the required wheel torque the motor must produce  $13.9/49 = 0.28$  Nm, or just over twice its continuous torque rating. Since the peak torque is only required for a short burst of time, this surge is acceptable because the average motor torque over the entire gait cycle is 0.056 Nm (43% of the motor's continuous torque rating). To keep the transmission as small and light as possible while preventing the leg from back driving the mechanism, a worm gear with a transmission ratio of 48:1 was selected. The operation region of the motor with this transmission is shown in Figure 4-7. Although the efficiency of worm gears is lower than other types of transmissions, the purpose of this research is to study the viability of the Scotch yoke mechanism as an exoskeleton actuator and not to improve the efficiency of exoskeletons.

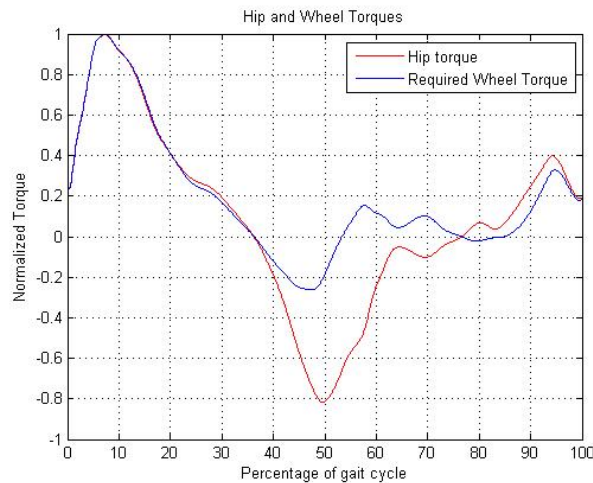
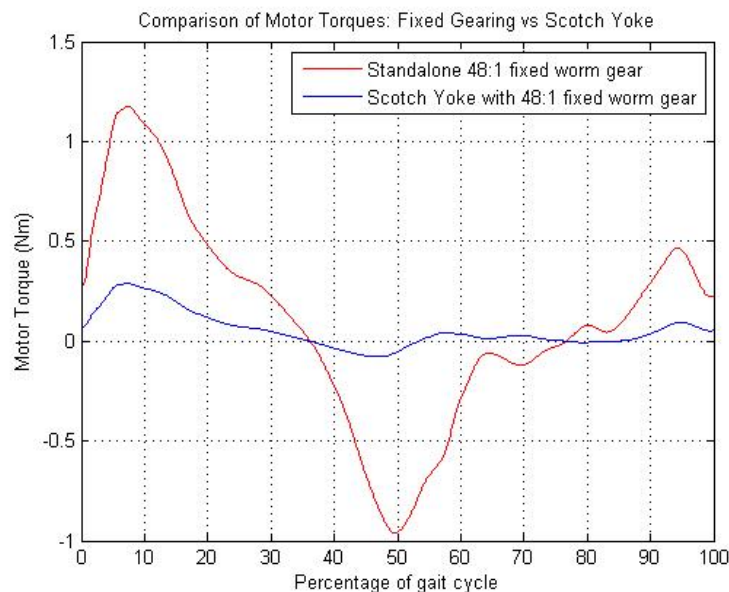

**Figure 4-8: Normalized hip and wheel torque profiles showing reduction in torque variation**

Figure 4-8 shows the normalized torque profiles for the hip joint and worm wheel. Both plots are normalized to their own maximum, not the maximum value of the two separate plots, to show the reduction in torque variation the Scotch yoke mechanism provides. While the hip torque varies from its maximum value on the positive side to 81% of that maximum on the negative side,

the wheel torque required to produce the hip torque varies from its maximum to only 26% of that maximum on the negative side. This reduction in negative torque is caused by a peak in the sinusoidal nature of the transmission ratio (Eq. 3.2).

While the Scotch yoke mechanism provides a reduction in torque variation, which improves the fatigue life of the transmission in the mechanism, it also provides a reduction in the peak torque and a reduction in the average torque squared. These properties allow a smaller, lighter motor to be used. The dominant losses in a DC motor are resistive losses through the windings. These losses are given by  $i^2R$  where  $i$  is the current through the motor and  $R$  is the resistance of the winding. Since the motor torque is directly related to the motor current, reducing the average torque reduces the average current and causes less motor heating. Figure 4-9 shows



**Figure 4-9: Comparison of required motor torque for fixed gearing vs Scotch yoke.**

the motor torque necessary to produce the required assistive torque at the hip for a fixed standalone 48:1 worm gear and the same worm gear coupled with a Scotch yoke mechanism. Worm gears have a low efficiency compared to other types of gearing, but to isolate the effect of the Scotch yoke on the performance of the exoskeleton actuator the gearing used in this

comparison is kept constant. It can be seen that the peak motor torque using the Scotch yoke mechanism is 25% of the torque for the worm gear alone. This is because the ratio  $r/h$  in Eq. 3.1 is set to 1/4 to control the maximum step size, but this ratio also controls the minimum transmission ratio of the Scotch yoke (Eq. 3.2). As mentioned earlier, the sinusoidal nature of the transmission ratio provides the reduction in the peak negative torque seen halfway through the gait cycle and allows the average motor torque to be reduced. The average motor torque squared for the standalone fixed 48:1 transmission is 0.284 Nm while the average for the Scotch yoke mechanism is 0.011 Nm. This reduction could allow a smaller, lighter motor to be used.

### **Series Elastic Elements**

During the gait cycle passive structures exert the negative torque seen in Figure 3-1(a) starting 35% of the way through the cycle. Since energy is being absorbed and dissipated by passive tissue during this phase, the power generation of the muscles is negative and it is possible for passive mechanical elements, such as springs, to absorb this energy instead of human tissue. Doing this would allow energy to be stored and later released during the next peak of positive power generation to reduce the energy spent walking.

In Figure 3-1(a) it can be seen that the maximum negative hip torque is -1.03 Nm/kg, which equates to -92.7 Nm for a 90 kg user. It can also be seen in Figure 3-1(b) that the hip has a maximum extension (moving backwards) angle of 6.2 degrees. With an actuator moment arm,  $h$ , of 10.16 cm (4.0 in) the linear displacement of the spring is 11.00 mm. A 10.16 cm moment arm requires 912 N of force to produce the peak torque of 92.7 Nm; the spring must provide 912 N when compressed 11.00 mm to provide 100% of the power needed. Since this actuation mechanism is only intended to provide 50% assistance to the user, the spring need only provide a peak of 456 N when compressed 11.00 mm. To meet this requirement, a spring with a stiffness of 41,470 N/m (236.5 lbs/in) was used to absorb the power dissipated during the negative power phase of walking.

These springs can also be used to measure the torque currently being exerted at the hip joint. To do this, one rotary encoder is connected before the springs to measure the rotation of the wheel and another is connected after the springs to monitor the rotation of the leg bar. If the motor were rigidly connected to the leg bar, it would oscillate back and forth in phase with the rotation of the wheel. If the leg bar was held stationary, the wheel would stop turning due to the rigid connection. Since the springs are not rigid there will be a phase lag between the leg bar and wheel rotation if external forces are applied to the leg bar. By measuring the difference between the wheel and leg bar encoders the rotational phase lag and therefore linear displacement can be determined, and the force can be calculated based on the known spring stiffness. Multiplying this force by the length of the leg bar,  $h$ , yields the applied hip torque.



## CHAPTER 5

### CONTROL APPROACH

To evaluate the mechanism, a prototype was built and controlled using a stiffness controller. Stiffness controllers are closely related to impedance controllers and are widely used in the field of rehabilitation robotics [25] [8]. Impedance control is a common method used to control robotic manipulators, and is currently used by the HAL exoskeleton. It relies on the principle that power flow between the manipulator and its environment can be described by effort (such as a force) and flow (such as velocity). If one object accepts effort and produces a flow (admittance) the other object must accept that flow and produce some resistive effort (impedance). Objects in an environment can be described by equations of motion that depend on boundary conditions, inertias, masses and other dynamic properties. While force can always be exerted on the environment by a manipulator, the object does not always move. If a manipulator and a fixed object in the environment interact with one another, the manipulator must yield since the object cannot move. Traditional proportional-derivative (PD) controllers work well for situations with known parameters operating in known environments, but they are not always desirable when operating in unknown environments where significant interaction forces may be encountered. For example, if an exoskeleton were controlled with only a PD controller it would enforce a particular gait pattern without regard to how the human responds to that motion. By controlling the perceived stiffness of the manipulator with a stiffness controller it is possible to track the desired trajectory while also controlling the interaction forces between the manipulator and environment.

The purpose of stiffness control in exoskeletons is to vary the amount of assistance provided to the user based on their current position and current resistance to further motion. When the stiffness is very high, the exoskeleton is in control of the user and it will move the leg the 'correct' way; it is acceptable to exert high forces on the user to enforce this pattern. When the stiffness is very low, the exoskeleton is constantly looking to the user to provide direction for

when to move and to what extent and provides very little assistance; it is trying to keep the interaction forces low at all times. Striking a balance between mirroring the user and dominating the user is necessary and the ability to change the stiffness in real time allows the exoskeleton to have a patient-in-charge mode and allow for the most comfortable user experience.

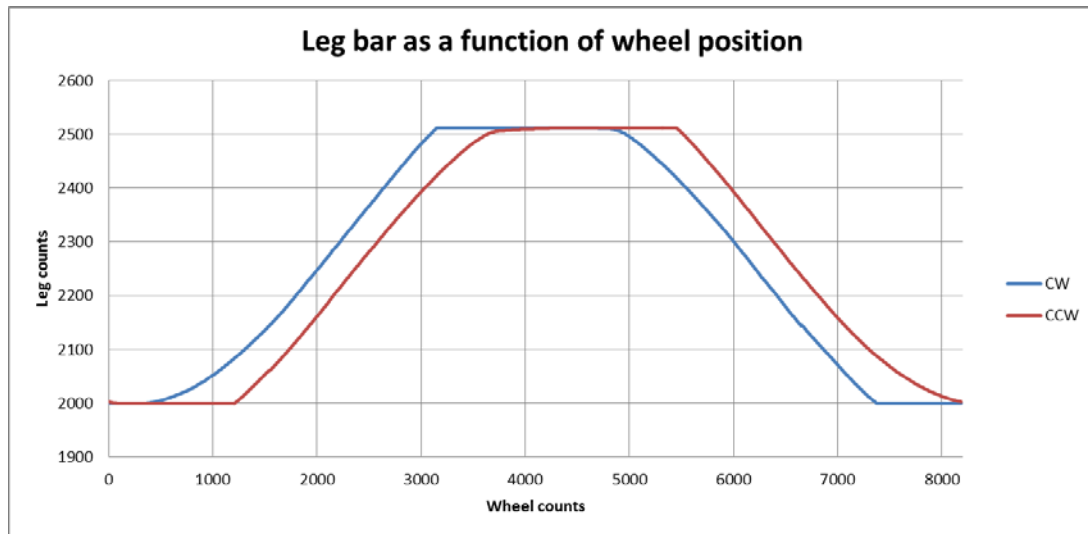

**Figure 5-1: Graphical representation of the lookup table the exoskeleton builds during its calibration procedure to infer spring deflection and measure backlash and every possible position.**

To detect the interaction force between the exoskeleton and the user, two rotary incremental encoders are used to measure the displacement between the leg bar that connects to the user and the worm wheel connected to the motor. If these two components were rigidly connected they would always move in phase and knowing the position of the worm wheel would give the position of the leg bar. Since the two components are connected via series elastic elements the leg bar can lag or lead the wheel position depending on the forces exerted by the user. When the exoskeleton is first powered on it runs a calibration routine to determine the “zero-force” position of the leg bar at every point along with wheel’s rotation. Figure 5-1 is a graphical representation of the internal lookup table the exoskeleton builds as it rotates clockwise and counterclockwise while storing the positions of both encoders. The two plots do not overlap because of the significant amount of backlash in the mechanism. Backlash is typically regarded as a problem in mechanical systems and can make control very challenging, but in exoskeleton

applications it can provide some benefits. When the control scheme is patient-in-charge the roller will stay in the center of the backlash region of the yoke (halfway between the blue and red lines in Figure 3-8) giving the user a small region to move completely unimpeded by the exoskeleton. If the patient follows the correct gait pattern in a zero-backlash system and the exoskeleton tries to keep the force at zero, the torque exerted on them by the exoskeleton is limited by the minimum resolution of the force sensors. In this mechanism, the minimum force that can be measured is 0.65 lbs (2.9N) so until the force reaches this level the exoskeleton will think the force is exactly zero and not move. This will provide slight resistance to the user and could impede their walking. By keeping the roller wheel in the center of the yoke's backlash during the gait cycle there will truly be zero resistance because the user's leg cannot move fast enough to pull the roller against the side of the yoke before the motor moves the yoke out of the way. If the backlash region was smaller (or nonexistent) the bandwidth requirements of the controller and motor would be higher.

Once the calibration routine is complete the exoskeleton uses the lookup table to determine the interaction force between the exoskeleton and the user. To do this it determines if the leg position is between the clockwise and counterclockwise positions in Figure 5-1. These positions define the left and right edges of the yoke and if the leg is between these two then it is in the zero-force backlash region. If the exoskeleton is in patient-in-charge mode it will move the wheel to keep the roller centered between the two edges of the yoke. If the leg's position is outside of the backlash region then one of the springs is being compressed and the linear displacement can be calculated using Equation 5.1:

$$x = \left( \frac{\text{backlash limit} - \text{leg counts}}{\text{encoder resolution}} \right) 2\pi h \quad \text{Eq. 5.1}$$

Where  $x$  is the linear displacement of the spring, *backlash limit* is the leg position corresponding to the blue or red line (depending if leg is lagging or leading), *leg counts* is the current position of

the leg bar as measured by the rotary encoder, and  $h$  is the distance from the center of the leg bar rotation to the attachment point of the cable. Multiplying the linear spring displacement by the spring constant of the spring being compressed yields the interaction force.

Since the relationship between the leg position and motor position is not linear (see Eq. 3.3) traditional linear control schemes will not be very effective if the leg position is directly used for feedback. However, since the relationship between leg position and wheel position is known (Figure 5-1) and there is a linear relationship between the motor and the wheel position, the position of the wheel can be controlled using a linear algorithm. The stiffness control law used for the exoskeleton is given by Equation 5.2:

$$\tau_m = k_m \left( \tau_{act} - k_t (\theta_{act} - \theta_{ref}) \right) \quad \text{Eq. 5.2}$$

Where  $\tau_m$  is the motor effort,  $k_m$  and  $k_t$  are tunable gains,  $\tau_{act}$  is the actual torque being applied to the leg by the exoskeleton, and  $\theta_{act} - \theta_{ref}$  is the position error between the actual leg position and the reference leg position. The gain  $k_t$  determines motor effort due to the error between the actual torque being applied to the hip (via interactions with the user's leg) and the torque that is supposed to be applied based on the position error. This gain term has the most pronounced effect on the stiffness of the mechanism. The gain  $k_m$  controls the effort used to correct for positioning errors. If it is too low, the exoskeleton's response lags the reference trajectory and if it is too high the system becomes unstable. Balancing these two gains allows the exoskeleton to follow a reference trajectory while applying an appropriate assistive force to the user. The gain constants in the control law were experimentally determined to be  $k_m = 6.0$  and  $k_t = 0.009$ .

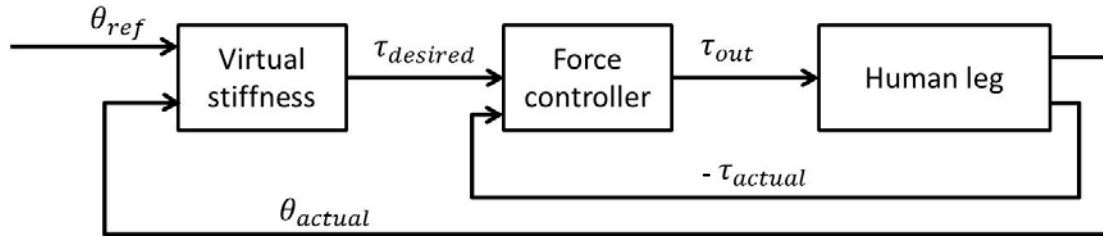

**Figure 5-2: Block diagram of the stiffness controller used to control the exoskeleton**

If the user's leg lags behind where it should be, the exoskeleton will provide an assistive force to move it forward. However, if the leg tries to get ahead of where it should be the exoskeleton will quickly move out of the way to allow the motion. This behavior is designed to improve safety since stopping a person mid-step can cause even a healthy person to fall.

To implement the controller shown in Figure 5-2, a 16-bit PIC microcontroller was used to read the encoder signals and generate motor control signals. The motor was controlled using a Maxon ESCON motor driver (#438725) and connected to a 32 VDC power supply. The motor driver handles commutation of the brushless DC motor and can supply 15 A at up to 50 VDC. It accepts a pulse width modulation (PWM) signal via a digital input that is used for either a current or velocity control reference. For this exoskeleton velocity control mode was used with a 50% duty cycle corresponding to zero velocity. Duty cycles shorter than or longer than 50% correspond to clockwise or counterclockwise rotation and the maximum velocity (set to 10,000 rpm) occurs at 90% or 10% duty cycle depending on the direction of rotation. Data collection was accomplished using a serial to USB cable to transfer data from the microcontroller to a Windows based PC in real time.

## CHAPTER 6

### MECHANICAL EVALUATION AND HUMAN SUBJECT TESTING

#### Mechanical Evaluation

To validate the mechanism and control scheme a series of bench tests were performed. Five sine waves, with periods varying from 4.0 to 0.33 seconds, were used as the reference signal to show the position tracking capabilities of the exoskeleton. The amplitude of these sine waves was set to cover the full range of motion of the device and no resistance was provided for the first stage of testing. Experimentally determined gain values of  $k_m = 6.0$  and  $k_t = 0.009$  were used for position tracking and the results can be seen in Figures 6-1 through 6-5 below. All the graphs start immediately after the initial calibration routine completes ( $t = 0$ ) and because of this they all show a large disparity between the reference and actual positions in the beginning. To correct this disparity the exoskeleton could force the actual position to rise very quickly and match the reference, but this would cause jerky leg motion and be uncomfortable to the user. Instead, the exoskeleton waits until the next “step” to begin following the reference trajectory. This is why all position tracking plots show the actual position as mostly flat at the start. Once tracking begins there is minimal tracking error within the first step.

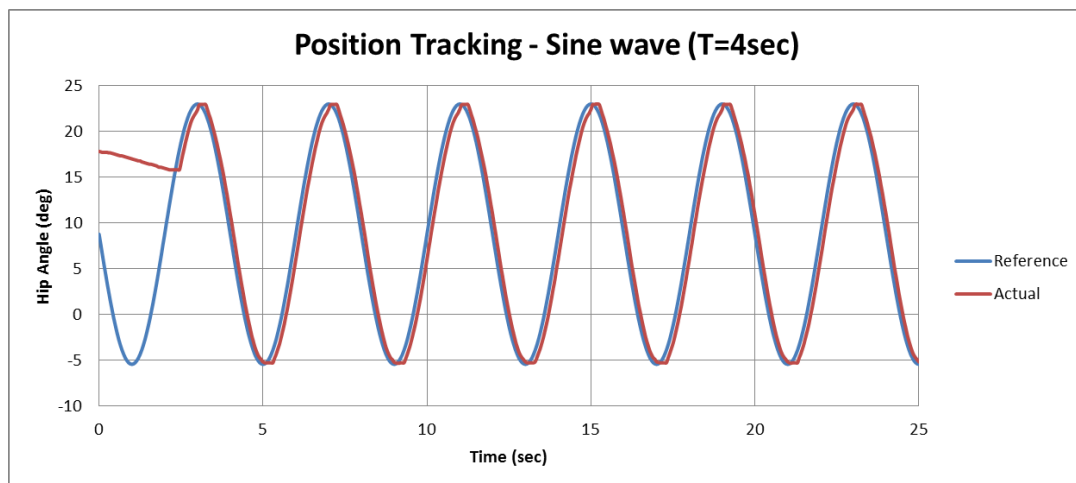

Figure 6-1: Position tracking of 0.25 Hz sine wave.

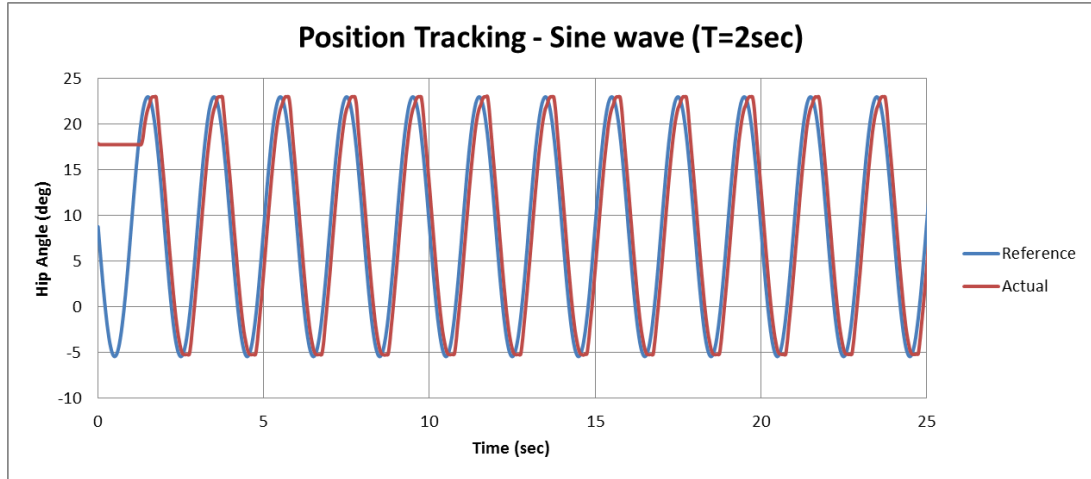

Figure 6-2: Position tracking of 0.5 Hz sine wave.

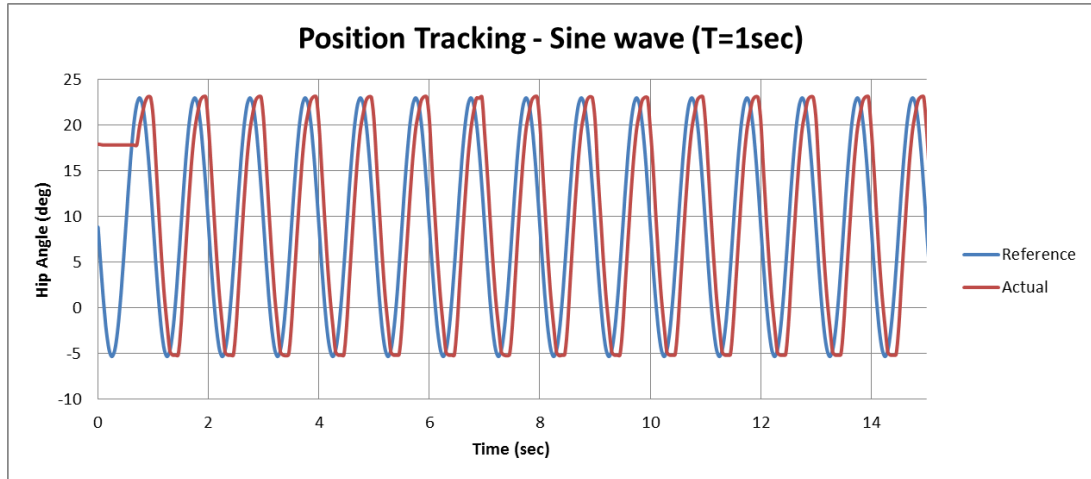

Figure 6-3: Position tracking of 1 Hz sine wave

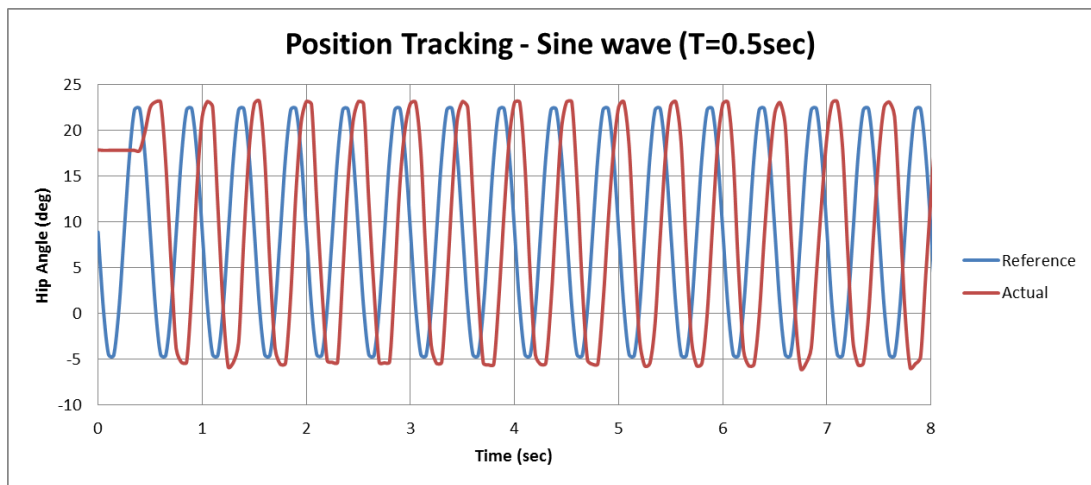
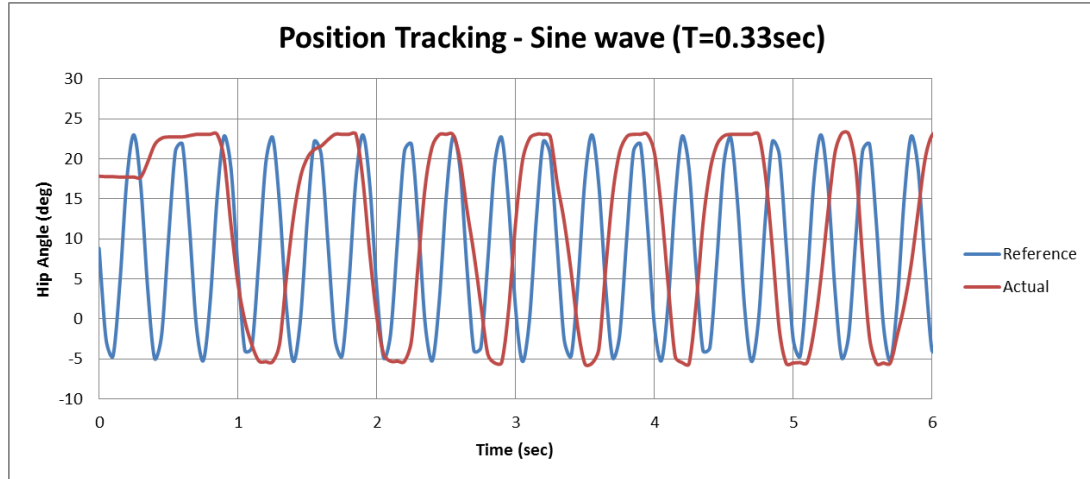

Figure 6-4: Position tracking of 2 Hz sine wave.



**Figure 6-5: Position tracking of 3 Hz sine wave.**

For the sine waves with periods of longer than one second, the exoskeleton tracks the reference position very closely. For the sine wave with a period of one second (Figure 6-3) there is a slight phase lag due to the faster motion. The period of a healthy human gait cycle is about 1.2 seconds [9] and the period of a mobility-impaired person will be slightly longer, which will reduce the mismatch between the reference and actual leg positions. Despite the slight lag in positioning, the period of the leg remains the same as the reference. Provided the period and step size remain the same, the user will be able to adapt to a phase shift within a step or two. The phase lag grows larger for reference signal with a half second period (2 Hz), but for the aforementioned reason the phase lag is acceptable and the exoskeleton is still stable. For sine waves with a period of 0.33 seconds (3 Hz), the output is still a sine wave but it is heavily distorted and the period is not constant or the same as the reference signal. At this speed and speeds faster than it the exoskeleton becomes unstable. Humans with impaired gait will not walk faster than 1Hz and since stable behavior continues until just past 2Hz the bandwidth of the exoskeleton and controller is sufficient.



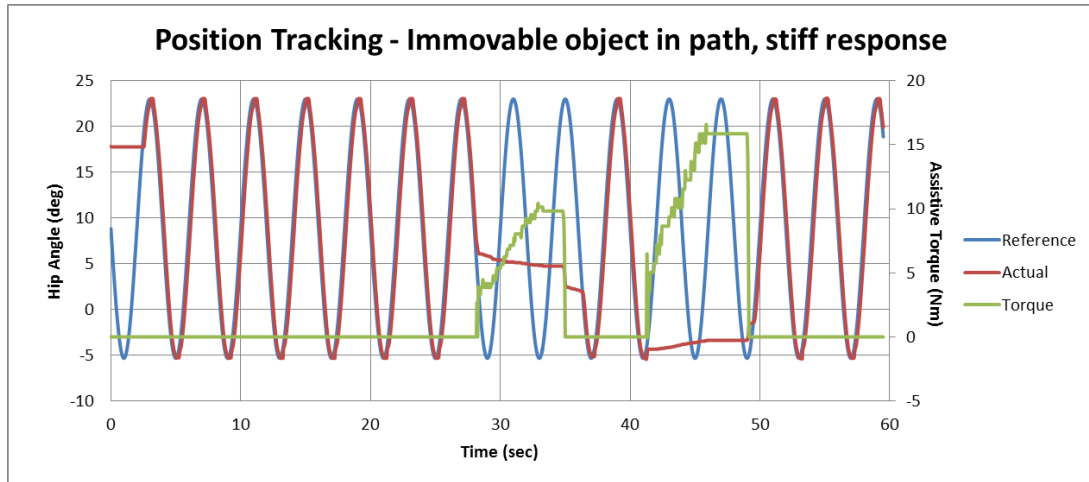

**Figure 6-6: Position tracking of a sine wave reference (0.25 Hz) with a stiff controller and an object put in the path of motion.**

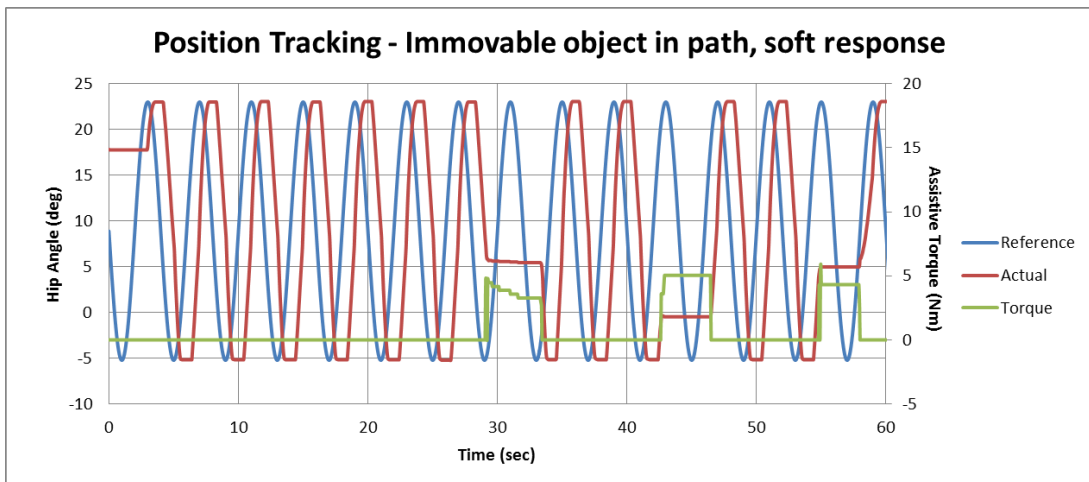
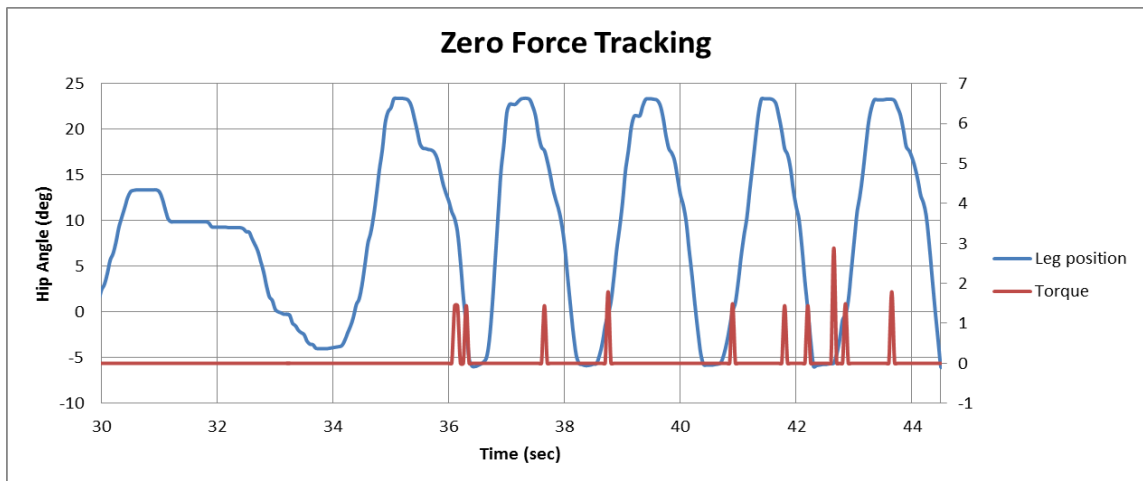

**Figure 6-7: Position tracking of a sine wave reference (4 second period) with a soft controller and an object put in the path of motion. The assistive torque is much lower than it was with the stiff controller.**

Next, an immovable object was placed in the path of the leg bar to show the effect different controller stiffness has on the response. Figure 6-6 shows the high stiffness response when  $k_t = 0.009$ . For the first several cycles the leg is free to move and the torque provided by the exoskeleton is zero. At  $t = 28$  seconds the object is put in the way, the torque begins to rise and the leg stops following the reference position. When the object is removed at  $t = 35$  seconds the exoskeleton goes back to following the reference signal. The object is put in the way again at  $t = 41$  seconds when the leg bar is moving in the opposite direction and the same behavior is seen:

the leg bar stops moving and the assistive torque continues to rise up to some limit until the object is removed and then the position tracking resumes. With this stiffness, the exoskeleton provides 16.6 Nm of torque before it stops trying to push harder. When  $k_i$  is reduced by 89% to 0.001 the controller stiffness drops dramatically. This softening of the system response is seen in Figure 6-7. The first observation is that the system no longer follows the reference position as accurately as it did when the stiffness was higher. This is because very low stiffness is equivalent to a PD controller with low gains; there will be steady state error and a delay in following the reference. There will also be lower interaction forces and the exoskeleton will provide less torque before it stops trying to move the object. When the object is placed in the path of the leg bar the leg bar's motion stops and the torque rises. This happens when the object is put in the way in both directions of motion, but the amount of torque the exoskeleton provides before stopping is less than before. Where 16.6 Nm of assistive torque was provided to the immovable object in Figure 6-6, the exoskeleton only provides a peak of 5.8 Nm of torque in Figure 6-7. By changing the stiffness of the controller, the amount of assistance the exoskeleton provides to the user can be modulated.

When the exoskeleton is put in a zero-force "learning mode" it will respond to user input



**Figure 6-8:** The controller is in learning mode and works to minimize the interaction torque (Nm) between the exoskeleton and user. The leg bar was pushed back and forth by hand and the motor moved the yoke out of the way to reduce the force.

by moving to minimize the interaction forces. This mode is used to track the user's leg during the learning phase of operation and ideally zero force would be exerted on the user by the exoskeleton to ensure the learned gait pattern is as natural as possible. Due to the resolution of the force sensors and motor reaction times it is not possible to have exactly zero force at all times, but keeping the interaction torque below 5% of the torque naturally produced by the user would be low enough to not significantly impede their gait. Figure 6-8 shows how the exoskeleton behaves in this configuration. The leg bar was manually moved to different positions and moved cyclically to simulate a possible gait pattern. As the bar was moved the exoskeleton moved the worm wheel to keep the interaction forces as low as possible. The maximum torque exerted by the exoskeleton on the user was 2.88 Nm, which for a 90 kg user is 2.6% of the maximum torque required to walk. This interaction torque is low enough to not impede the user's gait and shows that the zero force controller works.

### **Human Testing**

After getting IRB approval, the exoskeleton was tested on a healthy human subject to evaluate its assistive capabilities. The subject was a 27 year old male weighing 71 kg with no

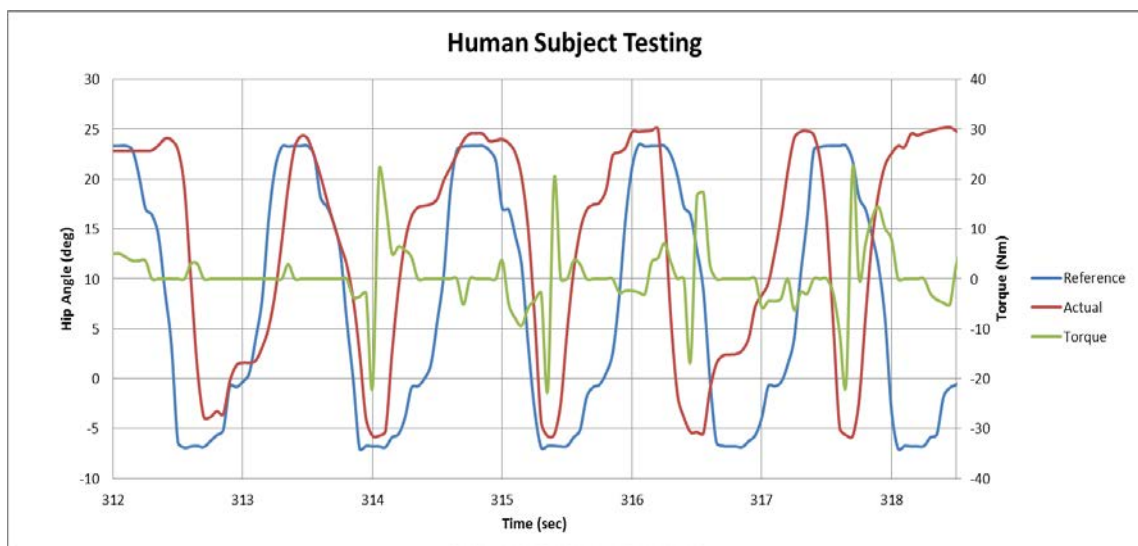

**Figure 6-9: Exoskeleton mounted to human subject.**

physical impairments or pre-existing medical conditions. The exoskeleton was mounted to a hip brace designed for resistance training of the hip joint to attach to the subject (see Figure 6-9). It was powered via a 32 VDC power supply for the motor driver and a 5 VDC supply for the logic. The reference trajectory, actual trajectory, and interaction force were sent in real time from the PIC microcontroller through a serial to USB cable and recorded on a Windows based PC. The subject walked at a constant self-selected speed of 1.5 mph (2.5 k/hr) on a level, powered treadmill.

To learn the gait pattern of this particular subject, the exoskeleton was put in a zero stiffness “tracking mode” where it provided no assistive force and simply followed the subject’s leg wherever it moved. The position data was collected for several steps and then programmed back into the exoskeleton and the stiffness was increased so the exoskeleton would provide an assistive force to help the subject replicate his own natural gait pattern.

The reference trajectory, actual trajectory and torque provided by the exoskeleton are shown for several steps in Figure 6-10. During the initial walking phase when gait data is collected, one of the series elastic springs stretches to allow the leg bar to move past its ordinary



**Figure 6-10: Reference and actual trajectories for several steps. Assistive torque is highest when the leg lags the reference.**

stop, which happens at around -6 degrees. The yoke cannot move the leg bar past this position but due to the series springs the user can pull it there, and this hyperextension of the leg bar is what slows the leg to a stop without using the motor. The compression of the springs is why the maximum and minimum values of the reference and actual trajectories do not appear to line up in the plot. This mismatch does not cause control problems because during the initial calibration routine the exoskeleton determines how far the yoke can move in both directions without spring compression and then corrects any set points that are given above or below these limits.

When the subject lags behind the reference trajectory the exoskeleton provides a positive torque to pull the leg toward the correct position. Depending on the stiffness of the controller it will pull with a differing amount of torque. In the middle of each step in Figure 6-10 there is a brief negative torque exerted on the user by the exoskeleton. A negative torque signifies the user getting ahead of the reference trajectory and the exoskeleton trying to prevent that. Normally this type of interaction would not happen because preventing the user from moving their leg ahead could cause them to fall, but this negative torque happens at the end of motion when the leg goes backward. This torque is provided by series elastic spring described earlier that performs the same function as the passive muscle fascia in the user's hip. Instead of requiring a large motor torque to stop the leg, the yoke hits the end of its range of motion and the series spring exerts the necessary force.

Another feature of Figure 6-10 is the drop in force when the error between the reference and actual leg position gets too great. When the subject falls significantly behind the reference trajectory the exoskeleton will revert to the zero-force mode for the remainder of that step. This prevents phasing errors between the user's path and the reference trajectory. These types of errors would cause the exoskeleton to move rapidly to get back on track and would be uncomfortable and unstable for the subject's gait. If they fall too far behind for one step the controller will wait until the next step and then try again. Turning up the controller's stiffness would reduce the tracking error and reduce phasing errors, but would also make it less sensitive to inputs from the

subject. The “correct” stiffness value depends on the rehabilitation goals and the preferences of the subject.

It is also not possible for this exoskeleton to force the subject to follow the correct gait pattern. Doing so would require more than 100% of the required gait torque and this exoskeleton is only designed to provide 50% for assistance. Overpowering the user to enforce a “healthy” gait pattern on them would not allow them to resist and slow down and could result in pain, instability and injuries. For this reason the reference and actual trajectories will not match all the time.

Figure 6-11 shows the behavior of the exoskeleton when the user fights the reference trajectory and the maximum torque is exerted. For the 71 kg subject used in this study the peak hip torque required for walking is 88 Nm based on data from [9]. For 50% assistance the exoskeleton must provide 44 Nm. The peak torque in Figure 6-11 is 44.6 Nm – just above the required torque for this subject.

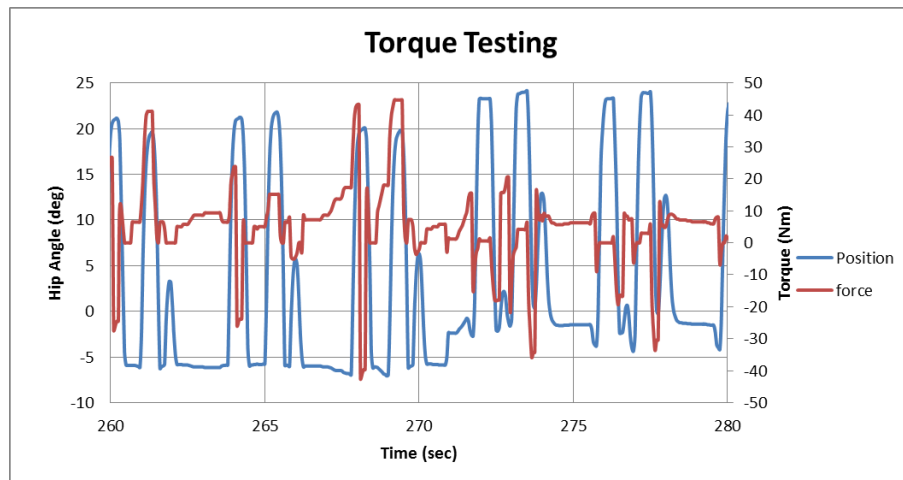
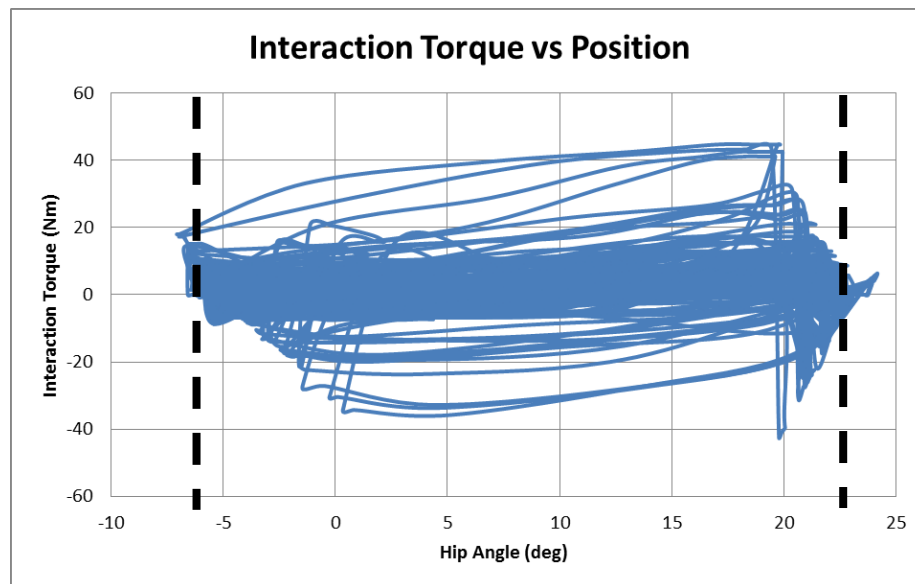

**Figure 6-11: Torque and position data when the user fights the exoskeleton and it provides its peak torque. For the 71 kg subject tested here, the exoskeleton must provide 44 Nm of torque and is successfully provided 44.6 Nm.**

### Passive vs Active Torque

Since the exoskeleton incorporates a non-backdriveable motor as well as series elastic elements it is possible for it to exert both passive and active torques on the user. Active torque is produced when the motor is moving the yoke to pull the user’s leg along the reference trajectory.

Passive torque is produced when the motor is not running (mechanism is locked in place) and the user pulls against the series elastic elements, which provide a corrective torque. Passive torque is also produced when the motor is running but the yoke is at either end of travel. At these locations the yoke does not move even though the motor is running and the series elastic elements are compressed to stop the user's leg from continuing to move. Figure 6-12 shows the assistive torque produced for several steps. The dashed lines show the end of travel of the yoke.



**Figure 6-12: Interaction torque between the exoskeleton and user for several gait cycles. Dashed lines show the yoke's end of travel.**

When the hip is fully flexed and the yoke reaches one end of travel (angle = -6 degrees) the interaction torque is passive and very low. This indicates the user was able to stop their leg without needing much passive torque from the series elastic springs. When the hip is fully extended and the yoke contacts the other end of travel (angle = 23 degrees) there is a moderate passive torque of approximately 15 Nm is developed by the interaction. This passive torque is larger since this spring was tuned to store the energy ordinarily stored by passive tissue in the hip joint (See Figure 3-1(c)). The yoke was designed to reach the end of travel before the user's hip is fully extended to ensure the spring is compressed. Between these two ends of travel the interaction torques are always actively produced by the motor. Evaluations of the series elastic

Scotch yoke mechanism have demonstrated that it can provide both active and passive torques during locomotion and that a peak active torque of 44 Nm is provided.



## CHAPTER 7

### CONCLUSIONS AND FUTURE WORK

The purpose of this project was to design, build and evaluate the performance of a Scotch yoke actuator for a powered hip exoskeleton. A stiffness controller was designed to limit the interaction forces between the exoskeleton and the user and it was tested on one healthy human subject in a laboratory setting. Simulations and experimental verification showed the actuator was capable of delivering the required torque and keeping up with the gait speed of a healthy human. Since the target population for this exoskeleton is physically impaired, it should have no problem keeping up with that gait speed as well.

The Scotch yoke mechanism used provides the benefit of converting continuous rotary motion to reciprocating linear motion. This means the electric motor does not have to reverse direction twice per step, each time overcoming its own inertia plus the inertia of the user's hip; this reduces the peak torque and reduces motor heating by reducing the average of torque squared. This metric is helpful because the dominant losses in DC motors are from current flowing through motor windings and by reducing the average motor torque the mechanism reduces the average motor current. Furthermore, when the mechanism reaches the ends of travel (when the leg is all the way forward and all the way backward) it is mechanically incapable of extending any further so the series elastic springs connecting the user's leg to the mechanism compress to slow the leg to a stop. This means that when the leg reverses direction there is no load on the motor since the geometry of the mechanism is locked in place and springs provide the resistive torque ordinarily provided by the user's muscles and passive muscle structures.

To learn the gait pattern of the subject the controller was set to "zero stiffness" so it moved out of the user's way and simply followed what they did. As the user walked, the exoskeleton collected position data at 50 Hz and logged it to a text file since the microcontroller does not have the memory to store more than a few seconds worth of data. The data points were then programmed into the exoskeleton and it would provide an assistive torque to help the user

replicated the gait pattern they previously used. The stiffness controller used accounts for both position errors and the interaction forces between the user and the exoskeleton. The controller works to reduce positioning errors while limiting the interaction forces. The amount of corrective torque applied depends on the size of the position error – larger position errors require more torque to be applied and as more torque is applied the controller starts to reduce the amount of assistive torque. Essentially the controller pushes up to a certain point and then becomes compliant. The amount of corrective torque provided is governed by two gain terms that regulate the stiffness of the control algorithm. By adjusting the stiffness the exoskeleton can go from “patient in charge” mode (low stiffness) where the exoskeleton provides no assistance to “exoskeleton in charge” mode (high stiffness) where the exoskeleton forces a gait pattern on the user with no regard for the amount of force being applied to the user. The “correct” stiffness value depends on the rehabilitation goals and the capabilities of the user.

If the user tries to move their leg faster than this reference trajectory the exoskeleton will move out of the way and allow them to do so; this behavior allows someone to take quick steps to prevent a fall in case they tripped or stumbled.

Although the Scotch yoke mechanism worked as designed, there are a few changes that should be made in the future to improve the overall performance of the system. First and foremost, the backlash that is used to provide a comfort region and true zero-force interaction ability caused more complications in reality than expected. While one of the benefits of the Scotch yoke mechanism is that it does not need to reverse direction to track a human’s gait pattern, it would be beneficial from a control perspective if it could reverse. If the user doesn’t move through the complete range of motion of the device, it needs to reverse direction and oscillate back and forth to take smaller steps. The significant backlash makes this nearly impossible to do accurately. The controller is also complicated by the position-dependent amount of backlash. Due to the sinusoidal path the roller that pushes the yoke follows, the amount of rotation needed to travel through the backlash region changes. To deal with this, a calibration

process runs to build a lookup table (Figure 5-1) and determine the size of the backlash at every position of the worm wheel. The calibration process is repeated every time the exoskeleton powers up and takes about 30 seconds to complete. The large and variable backlash could be eliminated by using a roller that is as close as possible to the width of the yoke while still being able to roll. This may reduce the exoskeleton's comfort to the user but a better controller that is capable of reversing direction may be able to mitigate this issue.

Another improvement would be to use a linear encoder to directly measure the compression of each of the two series elastic springs. Currently, the lookup table from Figure 5-1 is used by the controller to infer the compression of the springs based on the position mismatch between the leg bar and the worm wheel. This works, but is susceptible to drift if the cable loose tension over time or if the plunger pulling the spring doesn't come back to the exact same position once force is removed. Since this force is used in the control algorithm, it is important to have the fast, reliable and accurate measurements that would come from directly measuring the compression.

Future version of this exoskeleton should also incorporate a simpler way to adjust for step size variations between subjects. The current design requires the attachment point of the leg bar cable to be moved up or down to change the maximum step size. Doing this will change the actuator's moment arm and therefore the hip torque produced for a given motor torque so the exoskeleton would have to compensate for this after every adjustment. This type of adjustment currently requires new parts to be machined since everything is screwed into place, but if several set points were available the exoskeleton would work with a wider range of subjects.

Instead of following the user's own gait pattern, future versions should be capable of enforcing the gait pattern of a healthy individual. Healthy gait patterns provide the most energy efficient walking dynamic and individuals undergoing physical therapy typically have an altered gait pattern. Providing assistance to the subject is an important first step, but to truly help

rehabilitate the person's gait the exoskeleton should attempt to make corrections in addition to providing assistance.

One final improvement would be to replace the PIC microcontroller with a more powerful processor or a PC. The 16 bit dsPIC33F controller used in this prototype has 64k of memory and a processing speed of 80 MHz. If the controller were PC-based the exoskeleton could collect human gait data while in "learning mode" and after a few steps start using those data points as reference positions on its own. The backlash lookup table uses about 80% of the PIC's memory so there is not enough space to collect several seconds of gait data, average the data, and extract the necessary data points. Another limitation of this microcontroller is the processing speed: data cannot be output via the serial interface faster than 50Hz without causing delays in the control algorithm. 50Hz was fast enough since the frequency of human gait is 1-2Hz, but if more sensors were added or if the raw encoder data needed to be output in real time this microcontroller would not be capable of doing it. Before gait data was collected and directly used as set points for the reference trajectory, curve fitting was used and equations were programmed into the microcontroller. In theory this approach would work but due to computational limitations of the PIC the microcontroller kept resetting, most likely to memory overflow issues. A PC would be able to collect data and due real-time curve fitting without crashing and without needing to pause between the "learning" phase and the "assistive" phase to fit curves.

Overall the Scotch yoke mechanism is an acceptable way to actuate a hip exoskeleton, although some improvements should be made from this first prototype. Once these changes are made it should be possible to accurately control the exoskeleton to provide assistive torque in a rehabilitation setting to help restore normal gait patterns to injured persons.

## REFERENCES

- [1] Argo Medical Technologies. (2013, Feb. 7). Available at <http://www.ReWalk.com>.
- [2] Kawamoto, H., Lee, S. L. S., Kanbe, S., & Sankai, Y. (2003). Power assist method for HAL-3 using EMG-based feedback controller. *IEEE International Conference on Systems Man and Cybernetics*, 2, 1648–1653.
- [3] Ryder, Matthew C., and Frank Sup. "Leveraging gait dynamics to improve efficiency and performance of powered hip exoskeletons." *IEEE... International Conference on Rehabilitation Robotics:[proceedings]*. Vol. 2013. 2013.
- [4] A. B. Zoss, H. Kazerooni, and A. Chu, "Biomechanical design of the Berkeley lower extremity exoskeleton (BLEEX)," *IEEEASME Transactions on Mechatronics*, vol. 11, no. 2, pp. 128–138, 2006.
- [5] G. Colombo, M. Jorg, and V. Dietz, "Driven gait orthosis to do locomotor training of paraplegic patients," *Proceedings of the 22nd Annual International Conference of the IEEE Engineering in Medicine and Biology Society Cat No00CH37143*, vol. 4, no. 6, pp. 3159–3163, 2000.
- [6] J. F. Veneman, R. Ekkelenkamp, R. Kruidhof, F. C. T. Van Der Helm, and H. Van Der Kooij, "Design of a Series Elastic and Bowdencable-Based Actuation System for Use As Torque-Actuator in Exoskeleton-Type Training Robots," *9th International Conference on Rehabilitation Robotics 2005 ICORR 2005*, vol. 2005, pp. 496–499, 2005.
- [7] Veneman, J. F., Kruidhof, R., Hekman, E. E. G., Ekkelenkamp, R., Van Asseldonk, E. H. F., & Van Der Kooij, H. (2007). Design and evaluation of the LOPES exoskeleton robot for interactive gait rehabilitation. *IEEE Transactions on Neural and Rehabilitation Systems Engineering*, 15(3), 379–386.
- [8] R. Farris, H. Quintero, and M. Goldfarb, "Preliminary Evaluation of a Powered Lower Limb Orthosis to Aid Walking in Paraplegic Individuals," *IEEE Trans Neural Syst Rehabil Eng*, vol. 19, no. 6, pp. 652 – 9, 2011.
- [9] D. A. Winter, "Appendix A", *Biomechanics and motor control of human movement*, 4<sup>th</sup> ed., Hoboken, NJ: Wiley, 2009, pp. 341-351.
- [10] Kawamoto H, S. Y. (2002). Comfortable Power Assist Control Method for Walking Aid by HAL-3. *IEEE International Conference on Systems, Man and Cybernetics*, 1–6.
- [11] Hayashi, T., Kawamoto, H., & Sankai, Y. (2005). Control method of robot suit HAL working as operator's muscle using biological and dynamical information. *2005 IEEE/RSJ International Conference on Intelligent Robots and Systems*, 2(1), 3063–3068. doi:10.1109/IROS.2005.1545505
- [12] Kubota, S., Nakata, Y., Eguchi, K., Kawamoto, H., Kamibayashi, K., Sakane, M., ... Ochiai, N. (2013). Feasibility of Rehabilitation Training With a Newly Developed Wearable Robot for Patients With Limited Mobility. *Archives of Physical Medicine and Rehabilitation*, 94(6), 1080–1087. doi:10.1016/j.apmr.2012.12.020
- [13] Maeshima, S., Osawa, A., Nishio, D., Hirano, Y., Takeda, K., & Kigawa, H. (2011). Efficacy of a hybrid assistive limb in post-stroke hemiplegic patients : a preliminary report. *BMC Neurology*, 11(1), 116. doi:10.1186/1471-2377-11-116
- [14] Colombo, G., & Keller, T. (2003). Robotic Orthosis Lokomat : A Rehabilitation and Research Tool. *International Neuromodulation Society*, 3(2), 108–115.

- [15] Kazerooni, H., Racine, J., Huang, L., & Steger, R. (2005). On the Control of the Berkeley Lower Extremity Exoskeleton ( BLEEX ). *International Conference on Robotics and Automation*, (April), 4353–4360.
- [16] Japanese robot suit approved for worldwide rollout. (2013, February 27). *Business Insider*. Retrieved from <http://www.businessinsider.com/japanese-robot-suit-approved-for-worldwide-rollout-2013-2>
- [17] Exoskeleton helping disabled to walk. (2012, January 6). *United Press International*. Retrieved from [http://www.upi.com/Science\\_News/2012/01/06/Exoskeleton-helping-disabled-to-walk/UPI-53221325895641/?spt=hs&or=sn](http://www.upi.com/Science_News/2012/01/06/Exoskeleton-helping-disabled-to-walk/UPI-53221325895641/?spt=hs&or=sn)
- [18] Bernhardt, M., Frey, M., Colombo, G., & Riener, R. (2005). Hybrid Force-Position Control Yields Cooperative Behaviour of the Rehabilitation Robot L. *International Conference on Rehabilitation Robotics*, 536–539.
- [19] Riener, R., Lünenburger, L., & Colombo, G. (2006). Human-centered robotics applied to gait training and assessment. *The Journal of Rehabilitation Research and Development*, 43(5), 679. doi:10.1682/JRRD.2005.02.0046
- [20] H. Vallery, J. Veneman, E. Van Asseldonk, R. Ekkelenkamp, M. Buss, and H. Van Der Kooij, “Compliant actuation of rehabilitation robots,” *IEEE Robotics Automation Magazine*, vol. 15, no. 3, pp. 60–69, 2008.
- [21] D. W. Clausen, “Scotch Yoke”, U.S. Patent 2 366 237, Jan. 2, 1945.
- [22] V.L. Neuenschwander, “Scotch yoke piston and crankshaft connection with floating crank pin”, U.S. Patent 4 559 838, Dec. 24, 1985.
- [23] Veneman, J. F., Ekkelenkamp, R., Kruidhof, R., Van Der Helm, F. C. T., & Van Der Kooij, H. (2005). Design of a Series Elastic and Bowdencable-Based Actuation System for Use As Torque-Actuator in Exoskeleton-Type Training Robots. *9th International Conference on Rehabilitation Robotics 2005 ICORR 2005*, 2005, 496–499.
- [24] Chowdhury, Subhra, and Neelesh Kumar. "Estimation of Forces and Moments of Lower Limb Joints from Kinematics Data and Inertial Properties of the Body by Using Inverse Dynamics Technique." *Journal of Rehabilitation Robotics* 1.2 (2013): 93-98.
- [25] Lee, S., & S, Y. (2002). Power Assist Control for Walking Aid with HAL-3 Based on EMG and Impedance Adjustment around Knee Joint. *International Conference on Intelligent Robots and Systems*, (October), 1499–1504.